



SCANIA LOW ENTRY CITY BUS

BATTERY ELECTRIC CHASSIS



SCANIA

THE POWER OF THE CITY:

THE PEOPLE OF THE CITY

At Scania, we embrace the power of the city. The pulse, the everyday commute, the people who are relying on daily public transportation to work seamlessly – and that care about a sustainable future.

Cities are living beings made up by a collective of people, and our battery electric low-entry buses embody the power of collective movement – quite literally. But we offer far more than just vehicles: A holistic solution that defines the right products and services, and ensures the buses operate smoothly. From energy and charging infrastructure planning to vehicle specification and financing. And of course maintenance and the digital services that provide efficiency

and sustainability improvements on a day-to-day basis. Quite simply, a complete solution to ensure the buses are always able to be where they need to be, when they need to – and are operated as sustainably as possible from both a climate and business standpoint.

So, consider this a renewed promise that we will help you build a sustainable solution that works for your city – putting the future of the people first.



What solution is right for the people of your city?

The right solution starts from the prerequisites, the customer and tender demand. We would be happy to straighten out any question marks and help guide you to the solution you need.

SBTi

Scania was the first manufacturer of heavy commercial vehicles that committed to the Science Based Targets initiative (SBTi) – a joint initiative between global corporate actors to ensure progress towards the Paris agreement goals of limiting global warming to 2°C above pre-industrial levels.



SCIENCE
BASED
TARGETS

MORE THAN AN ELECTRIC BUS

A FULL SOLUTION FROM SCANIA

When it comes to electric buses it's about a lot more than just the vehicle itself. Electric operation brings new challenges in terms of route planning, charging infrastructure, maintenance, financing and the list keeps going.

In our opinion, those are quite simply challenges that shouldn't steal focus and time away from the key priority: the actual operation. For this very reason, the buses we offer come in the shape of a flexible solution covering vehicles, system aspects and surrounding services. All integrated, tailor-made to the specific needs or demands, and with Scania taking responsibility for every part of it.

Want help with charging infrastructure planning? Need introductions to

the right green energy partner? Would you benefit from operational planning support? Want to finance not only vehicles, but also charging infrastructure? Are repair and main-tenance staff in place or would a Scania workshop on your premises be helpful? No matter the context – we've got you covered.

Optimised total cost of ownership

The full solution is also what determines the operating economy. When factoring in every detail in the long-

term instead of looking at individual factors in the short-term – it's clear that you need a holistic approach with the right vehicles, a thought-through services setup and the appropriate supporting systems. As such, Scania has a holistic focus on efficiency – and that's the key for providing good return-on-investment.

BATTERIES IN THE BIGGER PICTURE

THE RIGHT BATTERIES, IN EVERY ASPECT

When it comes to electric vehicles, there's always one burning question: "But what about the batteries?" And we agree, that is most definitely a key question.

Discussions about the right batteries are important, covering key technical issues like range, capacity, battery management and charging speed. But it's also important to look at the batteries from the holistic perspective – the entire life cycle, from how they're made and all the way to what happens to them after they're no longer fit for the vehicle.

Demanding high standards

While we manufacture our battery packs in-house according to our highest standards, we also demand very high standards on our component suppliers in terms of both product

quality and sustainability aspects. Demanding not only specific suitability for long-term use in heavy commercial vehicles, but that every part of the manufacturing chain and transports is something we can stand behind.

The right capacity and range

All Scania buses come with an efficient powertrain. While this for conventional buses results in low fuel costs and emissions, in electric vehicles, it instead primarily enables an extensive range that facilitates planning and the transition to electric operations. However, battery capacity is not only about maximised range, but rather

about having the right amount of energy installed for the operation. It is important to also consider factors such as investment cost and battery weight to determine what is suitable in each case. Taking all factors into account, we provide guidance to make sure your buses have the right amount of installed energy according to specific prerequisites and needs – balancing the up-front investment and vehicle weight considerations with range. All to ensure your electric buses are as sustainable for your business as they are for the environment.



Participating in a public tender?

We value strong long-term partnerships and would gladly stand by your side from the start to help provide the strongest possible tender proposition.



OUR BATTERY ELECTRIC BUS PLATFORM

GREATER THAN THE SUM OF ITS PARTS



Our low-entry battery electric buses are great examples of how simultaneous updates to multiple parts and components come together to create a truly great vehicle. Like everything from the chassis with multiple width options, rear axle gears, the electric machine, and batteries – all the way to faster charging, and all the management systems and software gaining new features that provide a higher level of control.



Three, four or five battery packs

Our high-capacity battery packs enable a max range of over 500 km (5 battery pack option) in optimal conditions, and are built for great energy storage capacity per weight unit with cells that are developed specifically for heavy commercial vehicles. With options for three, four or five battery packs you can find the perfect balance between range, initial vehicle investment costs and vehicle weight. All while demanding high standards on suppliers in terms of both quality and sustainability aspects.



For cities all over the world

Our low-entry battery electric 4x2 and 6x2*4 buses come in two different chassis widths – 2,500 and 2,550 mm – and are suitable for usage all over the world in both medium and heavy-duty operations, in both Class I and Class II. Additionally, the multiple axle gear choices provide ratio options that work in even the most challenging topography.



Even safer – inside and out

Our multiple advanced state-of-the-art driver assistance systems (ADAS) provide the safest possible operation for the driver, the passengers and surrounding traffic. All while meeting the strict EU safety regulations for heavy commercial vehicles.



Smart, connected and future proof

Connected digital solutions enhance our vehicles with everything from advanced safety features and remote diagnostics, to real-time maps and geofencing functionality. And to help drivers quickly adopt the new technology, the Smart Dash provides the ultimate interface for confident electric operation in every sense – with a seamless user centric and dynamic approach. With continuous wireless updates and full integration in your fleet management tools – you are future proof.



Powerful and efficient electric machines

Our reliable and powerful electric machines offer optimised energy efficiency and are available at four power output levels – each matched with an appropriate two or four speed gearbox. They also come with an integrated cooling system and a continuously updated control system which meets the highest cyber security demands.



Fast, safe and flexible charging

We offer both front and rear charging options, with charging ports and batteries optimised for safety. And with the rear-charging option providing a high charging rate at up to 325 kW and 500 A – our battery packs and battery management system allows faster and better charging than ever before.



Questions about our engineering solutions & possibilities?

With tailor-made solutions as a core value, all Scania vehicles provide a strong basis for reliable, efficient, and flexible solutions. If you have thoughts on how to use the Scania platform to build the right bus for you – we would love to get into the details.

Scania K-chassis LE BEV

Our low-entry electric bus platform is designed to provide great vehicles from city to intercity routes, providing full confidence in tough conditions and heavy duty operations. It has been engineered to ensure simplified maintenance, a high level of cyber security, flexible bodybuilder adaptations, and to provide state-of-the-art smart and safe

features. Additionally, it comes with an all-new in-house developed battery management system to make the most out of the vehicle and its batteries both in the short and long term.

Chassis	- Low entry
Wheel configuration	- 4x2 - 6x2*4
E-machine	- 240 kW, 270 kW, 300 kW, 330 kW - Integrated 2- or 4-speed gearbox for optimised energy consumption
Battery capacity	- 267 kWh, 356 kWh, 445 kWh (3/4/5 battery packs)
Charging & position	- CCS type 2 - Front – up to 195 kW and 300 A - Rear – up to 325 kW and 500 A
Suspension	- RFS - Rigid front suspension 2,500 mm chassis width / smooth or uneven road

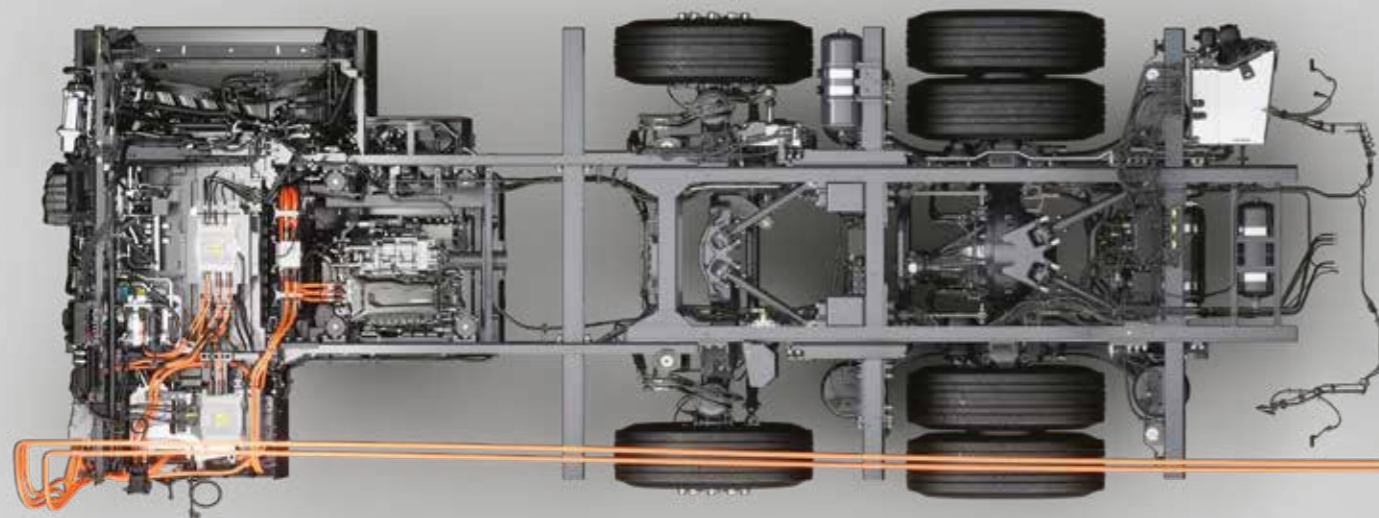

Battery options

3 battery packs		4 battery packs		5 battery packs	
Installed energy	267 kWh	Installed energy	356 kWh	Installed energy	445 kWh
Weight	~1,800 kg	Weight	~ 2,400 kg	Weight	~ 3,000 kg
Usable energy	240 kWh	Usable energy	320 kWh	Usable energy	400 kWh
Charging time	~52 min (415 km/h charge)*	Charging time	62 min (460 km/h charge)*	Charging time	~ 73 min (485 km/h charge)*
Life length	~675,000 km**	Life length	~ 900,000 km**	Life length	~ 1,125,000 km**

*Calculated for 5-95% SOC at 500A.

**Calculated with an energy throughput of 2,8 kWh/km (discharge + charge + regeneration) Average of 12,000 low entry buses.

Battery placement

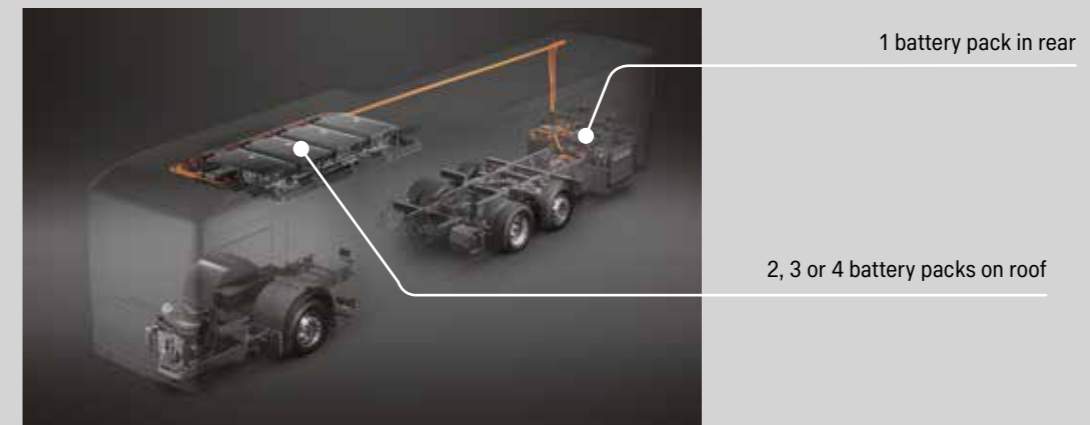

THE SERVICES TO BRING IT ALL TOGETHER

TURNING THE COMPLEX INTO SIMPLE

Electric operation brings new challenges and unknowns compared to traditional operations – making the goal of our services offer to ensure that you always feel confident and well-supported in your operations.



Financing and insurance

We have developed a financing offering that covers not only vehicle costs, but also infrastructure investments, insurance tailored for electric vehicles, and which is available with multiple payment models.



Uptime services

Well-scheduled periodic maintenance and quick and accessible repairs are available through our best-in-class global service network with high-voltage certified mechanics. And thanks to our modular system – we have outstanding parts availability for repairs.



Driver services

Driver behaviour influences not only traffic safety and wear and tear of the vehicle, but as much as 15% of the energy consumption – affecting range and energy costs. Scania buses come with a driver evaluation function that is integrated both with the Driver app, the in-vehicle Smart Dash and the My Scania platform, providing direct feedback on areas to improve and tips on how.

TOWARDS CIRCULAR BUSINESS

Together with our partners and with strategically located hubs, we are actively working to establish an ecosystem that supports circularity for our battery packs and the cells within.

Re-use

Reuse is the first option in circular economy. A good example is mid-life renovation, where instead of mounting brand-new batteries that would outlast the vehicles, reused batteries whose lifetime matches the remaining vehicle lifespan can be installed.

Re-purpose

Even after reaching the end of their life in the vehicle, batteries can be used for solutions and products such as Battery Energy Storage Systems (BESS). These systems can provide frequency balancing services to grid operators as more renewable energy sources are introduced, or to boost underpowered local electric grids, e.g. at bus depots.

Re-cycle

When the battery has reached a stage where it cannot be reused or repurposed, Scania has partnerships and infrastructure in place where precious raw materials such as cobalt are recycled to reduce the need for virgin material in the production of new batteries.



LIFE CYCLE ANALYSIS

Life cycle analysis insights are key to ensure that climate impact is truly addressed rather than just shifted or attributed to other sectors, industries and stakeholders. Since every aspect of a product life cycle can offer opportunities to increase overall sustainability – they are all

important. From raw material extraction and sourcing, to production and manufacturing. But also when the product is in use by our customers, and all the way to the circular business strategy that addresses second-life and end-of-life.

For more information please contact your nearest Scania team member.

Scania Bus and Coach Sales team contacts

Jamie Atkinson
VIC/TAS/SA/WA
0408 059 501

Steve Godbold
SA
0408 828 885

Shane Simpson
NSW
0411 768 027

Ian Clarke
NSW/ACT/QLD/NT
0438 482 492

Darcy Grant
WA
0478 310 518

Brian Thompson
QLD
0418 531 632

Scania Australia branch locations

VICTORIA

Campbellfield
212 – 216 Northbourne Road
Campbellfield VIC 3061
Tel: 03 9217 3300

Dandenong
2/66 Greens Road
Dandenong South VIC 3175
Tel: 03 9217 3600

Laverton
125-129 Boundary Road
Laverton VIC 3026
Tel: 03 8331 6300

QUEENSLAND

Richlands
149 Archerfield Road
Richlands QLD 4077
Tel: 07 3712 8500

Pinkenba
213 Holt Street
Pinkenba QLD 4008
Tel: 07 3712 7900

SOUTH AUSTRALIA

Wingfield
218-234 Cormack Road
Wingfield SA 5013
Tel: 08 8406 0200

NEW SOUTH WALES

Prestons
16 Lyn Parade
Prestons NSW 2170
Tel: 02 9825 7900

Eastern Creek
2 Blue Metal Road
Eastern Creek NSW 2766
Tel: 02 9825 7999

WESTERN AUSTRALIA

Kewdale
527 –529 Abernethy Road
Kewdale WA 6105
Tel: 08 9360 8500

Hope Valley
6 Armstrong Road
Hope Valley WA 6165
Tel: 08 9360 8580