

# DC09 071A. 267-292 kW (304-328 kVA)

EU Stage IIIA, China Phase III and CPCB-II

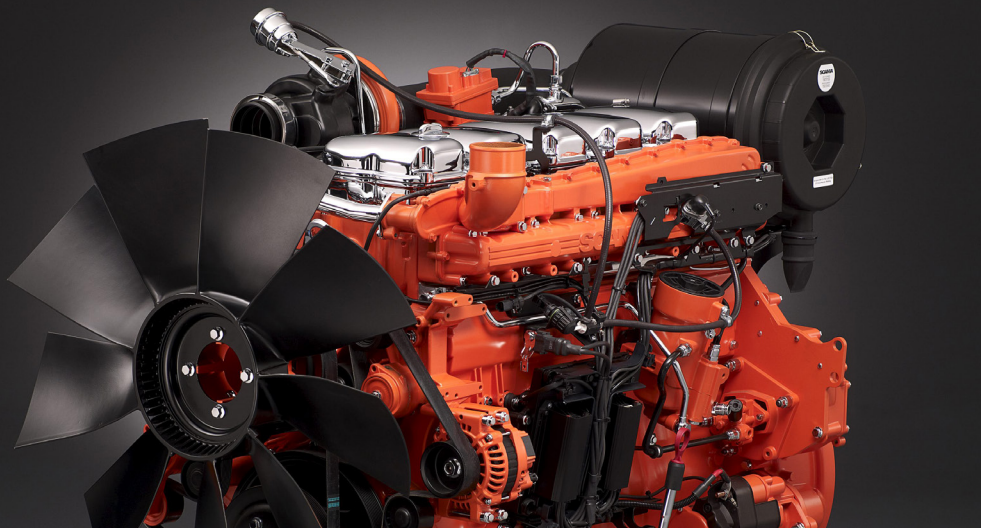

The engines for power generation from Scania are based on a robust design with a strength optimised cylinder block containing wet cylinder liners that can easily be exchanged. Individual cylinder heads with 4 valves per cylinder promotes reparability and fuel economy.

The engine is equipped with a Scania developed Engine Management System, EMS, in order to ensure the control of all aspects related to engine performance.

The injection system is based on electronically controlled unit injectors that gives low exhaust emissions with good fuel economy and a high torque. For further reduction of NO<sub>x</sub> emissions the engines are also equipped with an exhaust gas recirculation, EGR, system developed by Scania. The engine can be fitted with many accessories such as air cleaners, radiators and PTOs in order to suit a variety of installations.

	Engine speed (rpm)	
	1500 rpm (50 Hz)	1800 rpm (60 Hz)
	PRP	PRP
Gross power (kW)	267	292
Gross power (kVA)	304	328
Spec fuel consumption. Full load (g/kWh)	205	207
Spec fuel consumption. 3/4 load (g/kWh)	214	215
Spec fuel consumption. 1/2 load (g/kWh)	217	219
Heat rejection to coolant (kW)	119	128

**PRP – Prime power:** For continuous operation at varying load. Max mean load factor of 70% of rated power over 24 h of operation. 1 hour/12 hours period of accumulated peak overload to 110%.

### Standard equipment

- Scania Engine Management System, EMS
- Unit injectors, PDE
- Turbocharger
- Fuel filter and extra pre-filter with water separator
- Oil filter, full flow
- Centrifugal oil cleaner
- Oil cooler, integrated in block
- Oil filler, in valve cover
- Deep front oil sump
- Oil dipstick, in block
- Magnetic drain plug for oil draining
- Starter, 1-pole 6.0 kW
- Alternator, 1-pole 100A
- Flywheel, SAE 14
- Silumin flywheel housing, SAE 1 flange
- Front-mounted engine brackets
- EGR system
- Open crankcase ventilation
- Operator's manual

### Optional equipment

- Cooling package
- Fan
- Side-mounted PTO
- Exhaust connections
- Instrument panel
- Engine heater
- Stiff rubber engine suspension
- Air cleaner
- Closed crankcase ventilation
- Studs in flywheel housing
- Low coolant level reaction
- Fine tune potentiometer
- Ramp start delay
- Ramp up rate

# DC09 071A. 267-292 kW (304-328 kVA)

EU Stage IIIA, China Phase III and CPCB-II

## Engine description

No of cylinders	5 in-line
Working principle	4-stroke
Firing order	1-2-4-5-3
Displacement	9.3 litres
Bore x stroke	130 x 140 mm
Compression ratio	16:1
Weight	950 kg (excl oil and coolant)
Piston speed at 1500 rpm	7.0 m/s
Piston speed at 1800 rpm	8.4 m/s
Camshaft	High position alloy steel
Pistons	Aluminium pistons
Connection rods	I-section press forgings of alloy steel
Crankshaft	Alloy steel with hardened and polished bearing surfaces
Oil capacity	32-38 dm <sup>3</sup>
Electrical system	1-pole 24V

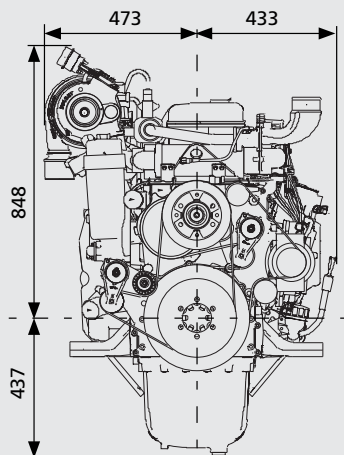
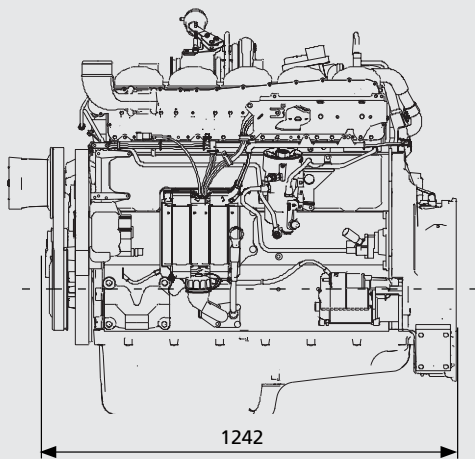

All dimensions in mm



SE 151 87 Södertälje, Sweden  
 Telephone +46 8 553 810 00  
 Telefax +46 8 553 829 93  
[www.scania.com](http://www.scania.com)  
[engines@scania.com](mailto:engines@scania.com)