

# DI16 090M. 480-553 kW

IMO Tier II

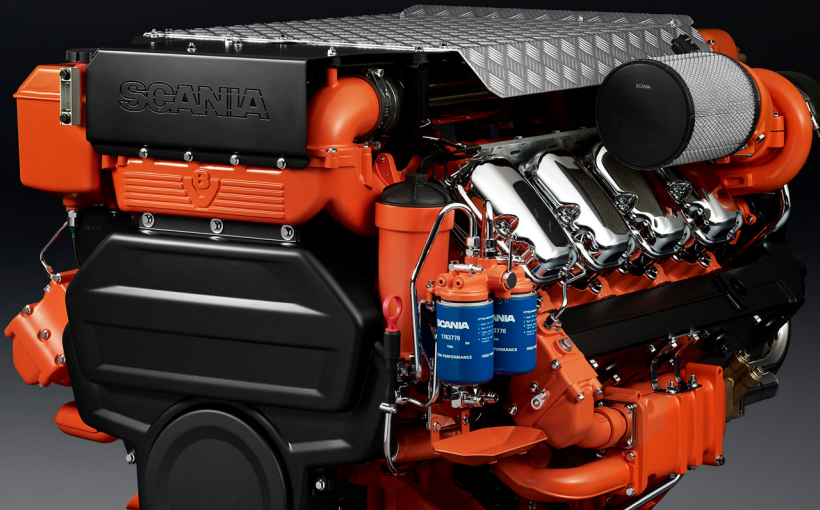

The marine engines from Scania are based on a robust design with a strength optimized cylinder block containing wet cylinder liners that can easily be exchanged. Individual cylinder heads with 4 valves per cylinder promotes reparability and fuel economy. The engines are type-approved in all major classification societies.

The engine is equipped with a Scania developed Engine Management System, EMS, to ensure the control of all aspects related to engine performance.

The injection system is based on electronically controlled unit injectors, which gives low exhaust emissions with good fuel economy and a high torque already at low revs. The engine can be fitted with many accessories such as air cleaners, PTOs and instrumentation to suit a variety of installations.

	Engine speed (rpm)	
	1500	1800
Gross power, full load (kW)	480	553
Gross torque (Nm)	3056	2934
Fuel consumption at full load (g/kWh)	240	277
Fuel consumption at 3/4 load (g/kWh)	194	201
Fuel consumption at 1/2 load (g/kWh)	194	199
Heat rejection to coolant (kW)	362	427

**Rating: PRP - Prime power**

For continuous operation and unlimited yearly operating time at varying load. Max. mean load factor of 70% of rated power over 24 h of operation. 1 hour/12 hour period above 100% load. Max. 25 h accumulated service time above 100% load per year.

**Standard equipment**

- Scania Engine Management System, EMS
- Unit injectors, PDE
- Twin turbochargers, heat insulated
- Fuel pre-filter with water separator
- Fuel filter
- Oil filter, full flow
- Centrifugal oil cleaner
- Oil cooler, integrated in cylinder block
- Oil filler, in valve cover
- Deep front oil sump
- Oil dipstick, front
- Starter motor, 2-pole 7.0 kW
- Alternator, 2-pole 100 A
- Flywheel SAE 14
- Silumin flywheel housing, SAE 1 flange
- Front-mounted engine suspension
- Catwalk and cover for belt transmission
- Closed crankcase ventilation

*Engines with heat exchanger:*

- Sea water charge air cooler
- Sea water pump
- Dual heat exchangers with expansion tanks

**Optional equipment**

- Scania Instrumentation 2.1
- Hydraulic pump
- Side-mounted PTO
- Front-mounted PTO
- Exhaust connections
- Engine heater
- Power pack engine suspension
- Stiff rubber suspension
- Air cleaner
- Studs in flywheel housing
- Reversible fuel filter
- Variable idle speed setting
- Low oil sump
- Oil draining with pump
- Coolant level monitor
- Oil level sensor
- Bilge pump



# DI16 090M. 480-553 kW

IMO Tier II

### Engine description

No of cylinders	V 8
Working principle	4-stroke
Firing order	1 - 5 - 4 - 2 - 6 - 3 - 7 - 8
Displacement	16.4 litres
Bore x stroke	130 x 154 mm
Compression ratio	16.7:1 - engine with heat exchanger 17.4:1 - engine with keel cooling
Weight (excl oil and coolant)	1670 kg - engine with heat exchanger 1600 kg - engine with keel cooling
Piston speed at 1500 rpm	7.7 m/s
Piston speed at 1800 rpm	9.24 m/s
Camshaft	High position alloy steel
Pistons	Steel pistons
Connection rods	I-section press forgings of alloy steel
Crankshaft	Alloy steel with hardened and polished bearing surfaces
Oil capacity	40-48 dm <sup>3</sup> (standard oil sump)
Electrical system	2-pole 24 V DC

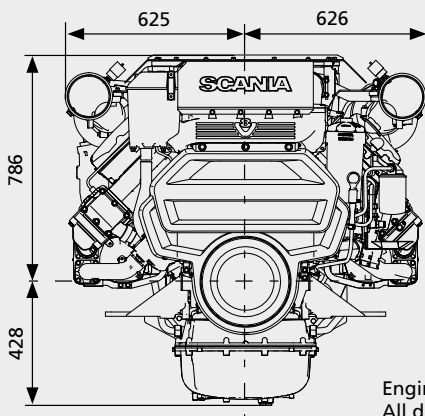
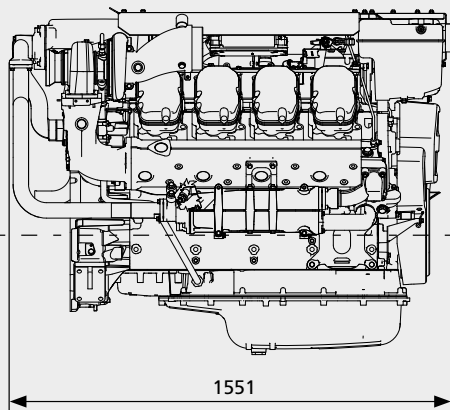

Engine with heat exchanger  
All dimensions in mm



# SCANIA

SE 151 87 Södertälje, Sweden  
Telephone +46 8 553 810 00  
www.scania.com  
powersolutions@scania.com