

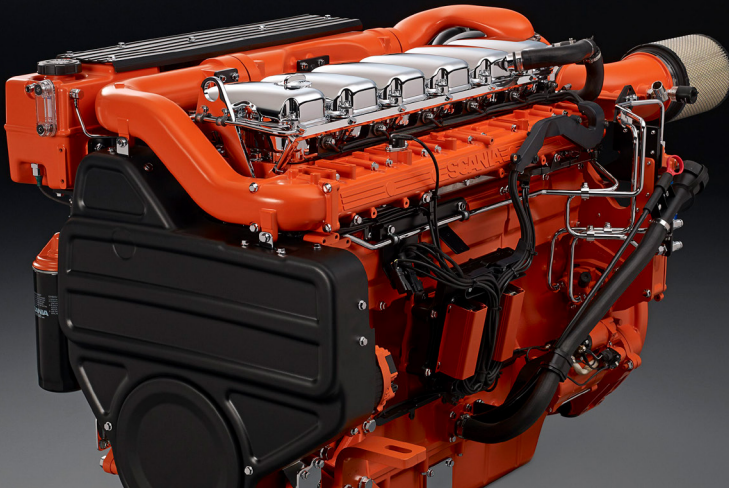

DI13 074M. 376-426 kW

IMO Tier II, US Tier 2, EU Stage IIIA



The marine engines from Scania are based on a robust design with a strength optimized cylinder block containing wet cylinder liners that can easily be exchanged. Individual cylinder heads with 4 valves per cylinder promotes reparability and fuel economy. The engines are type-approved in all major classification societies.

The engine is equipped with a Scania developed Engine Management System, EMS, to ensure the control of all aspects related to engine performance.

The injection system is based on electronically controlled unit injectors, which gives low exhaust emissions with good fuel economy and a high torque already at low revs.

The engine can be fitted with many accessories such as air cleaners, PTOs, and instrumentation to suit a variety of installations.

Standard equipment

- Scania Engine Management System, EMS
- Unit injectors, PDE
- Turbocharger
- Fuel pre-filter with water separator
- Fuel filter
- Oil filter, full flow
- Centrifugal oil cleaner
- Oil cooler, integrated in cylinder block
- Oil filler, in cylinder block
- Oil dipstick, in cylinder block
- Starter motor, 2-pole 7.0 kW
- Alternator, 2-pole 100 A
- Flywheel SAE 14
- Silumin flywheel housing, SAE 1 flange
- Front-mounted engine suspension
- Protection covers
- Sea water pump
- Heat exchanger with expansion tank
- Closed crankcase ventilation

Optional equipment

- Scania Instrumentation 2.1
- Hydraulic pump
- Side-mounted PTO
- Front-mounted PTO
- Exhaust connections
- Accelerator position sensor
- Engine heater
- Power pack engine suspension
- Stiff rubber suspension
- Air cleaner
- Studs in flywheel housing
- Reversible fuel filter
- Low coolant level reaction
- Low and extra low oil sump
- Long oil dipstick
- Oil level sensor
- Coolant level monitor
- Bilge pump

	Engine speed (rpm)	
	1500	1800
Gross power (kW)	376	426
Gross torque (Nm)	2400	2260
Fuel consumption at full load (g/kWh)	199	203
Fuel consumption at 3/4 load (g/kWh)	200	203
Fuel consumption at 1/2 load (g/kWh)	202	204
Heat rejection to coolant (kW)	260	303

Rating: PRP - Prime power

For continuous operation and unlimited yearly operating time at varying load. Max. mean load factor of 70% of rated power over 24 h of operation. 1 hour/12 hour period above 100% load. Max. 25 h accumulated service time above 100% load per year.

This specification may be revised without notice.



DI13 074M. 376-426 kW

IMO Tier II, US Tier 2, EU Stage IIIA

Engine description

No of cylinders	6 in-line
Working principle	4-stroke
Firing order	1 - 5 - 3 - 6 - 2 - 4
Displacement	12.7 litres
Bore x stroke	130 x 160 mm
Compression ratio	16.3:1
Weight	1285 kg (excl oil and coolant)
Piston speed at 1500 rpm	8.0 m/s
Piston speed at 1800 rpm	9.6 m/s
Camshaft	High position alloy steel
Pistons	Steel pistons
Connection rods	I-section press forgings of alloy steel
Crankshaft	Alloy steel with hardened and polished bearing surfaces
Oil capacity	30-36 dm ³ (standard oil sump)
Electrical system	2-pole 24 V DC

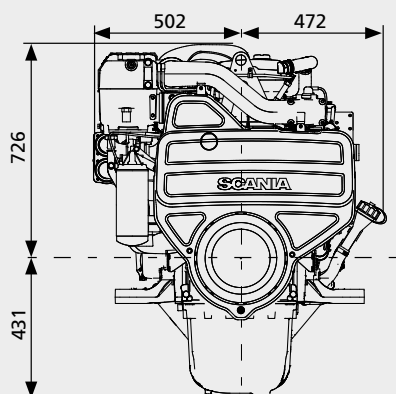
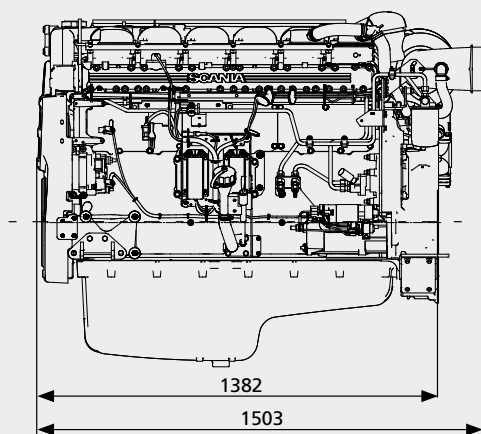

SCANIA

SE 151 87 Södertälje, Sweden
Telephone +46 8 553 810 00
www.scania.com
powersolutions@scania.com