

# DI09 074M. 269 kW

IMO Tier II, EU Stage IIIA

EMERGENCY / HARBOUR

*Without heat exchanger and water-cooled CAC*

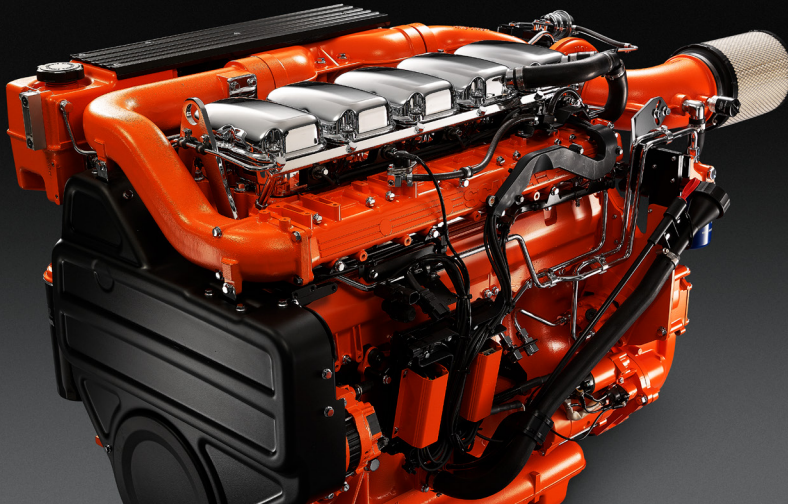

The marine engines from Scania are based on a robust design with a strength optimized cylinder block containing wet cylinder liners that can easily be exchanged. Individual cylinder heads with 4 valves per cylinder promotes reparability and fuel economy. The engines are type-approved in all major classification societies.

The engine is equipped with a Scania developed Engine Management System, EMS, to ensure the control of all aspects related to engine performance.

The injection system is based on electronically controlled unit injectors, which gives low exhaust emissions with good fuel economy and a high torque already at low revs.

The engine can be fitted with many accessories such as air cleaners, PTOs, and instrumentation to suit a variety of installations.

### Standard equipment

- Scania Engine Management System, EMS
- Unit injectors, PDE
- Turbocharger
- Fuel pre-filter with water separator
- Fuel filter
- Oil filter, full flow
- Centrifugal oil cleaner
- Oil cooler, integrated in cylinder block
- Oil filler, in cylinder block
- Oil dipstick, in cylinder block
- Starter motor, 2-pole 7.0 kW
- Alternator, 2-pole 100 A
- Flywheel SAE 14
- Silumin flywheel housing, SAE 1 flange
- Front-mounted engine suspension
- Protection covers
- Closed crankcase ventilation

### Optional equipment

- Scania Instrumentation 2.1
- Hydraulic pump
- Side-mounted PTO
- Front-mounted PTO
- Exhaust connections
- Accelerator position sensor
- Engine heater
- Power pack engine suspension
- Stiff rubber suspension
- Air cleaner
- Studs in flywheel housing
- Reversible fuel filter
- Variable idle speed setting
- Low oil sump
- Long oil dipstick
- Oil level sensor
- Coolant level monitor
- Bilge pump

	Engine speed (rpm)	
	1500	1800
Gross power, full load (kW)	269	269
Gross torque (Nm)	1713	1427
Fuel consumption at full load (g/kWh)	196	199
Fuel consumption at 3/4 load (g/kWh)	194	200
Fuel consumption at 1/2 load (g/kWh)	200	207
Heat rejection to coolant (kW)	188	193

### Rating: PRP - Prime power

For continuous operation and unlimited yearly operating time at varying load. Max. mean load factor of 70% of rated power over 24 h of operation. 1 hour/12 hour period above 100% load. Max. 25 h accumulated service time above 100% load per year.

This specification may be revised without notice.



# DI09 074M. 269 kW

IMO Tier II, EU Stage IIIA

*EMERGENCY / HARBOUR*

*Without heat exchanger and water-cooled CAC*

### Engine description

No of cylinders	5 in-line
Working principle	4-stroke
Firing order	1 - 2 - 4 - 5 - 3
Displacement	9.3 litres
Bore x stroke	130 x 140 mm
Compression ratio	18:1
Weight	1032 kg (excl oil and coolant)
Piston speed at 1500 rpm	7.0 m/s
Piston speed at 1800 rpm	8.4 m/s
Camshaft	High position alloy steel
Pistons	Aluminum pistons
Connection rods	I-section press forgings of alloy steel
Crankshaft	Alloy steel with hardened and polished bearing surfaces
Oil capacity	32-38 dm <sup>3</sup> (standard oil sump)
Electrical system	2-pole 24 V DC

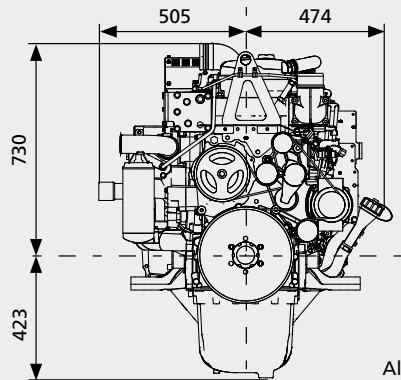
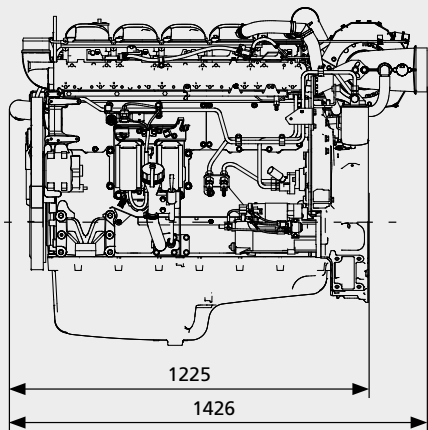

All dimensions in mm



**SCANIA**

SE 151 87 Södertälje, Sweden  
Telephone +46 8 553 810 00  
www.scania.com  
powersolutions@scania.com