

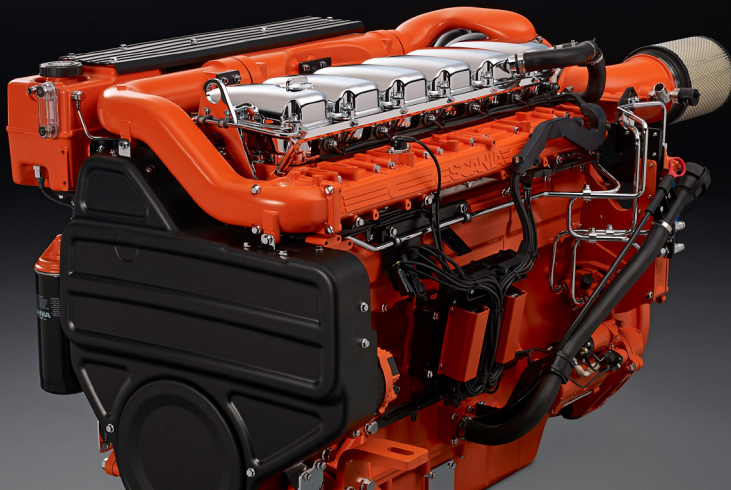

DI13 092M. 331 kW (450 hp)

IMO Tier III, EU Stage IIIA



The marine engines from Scania are based on a robust design with a strength optimised cylinder block containing wet cylinder liners that can easily be exchanged. Individual cylinder heads with 4 valves per cylinder promotes repairability and fuel economy.

The engine is equipped with a Scania developed Engine Management System, EMS, in order to ensure the control of all aspects related to engine performance. The injection system is based on electronically controlled unit injectors that in combination with SCR (Selective Catalytic Reduction) gives low exhaust emissions with good fuel economy and a high torque already at low revs.

The engine can be fitted with many accessories such as air cleaners, PTOs, transmissions, cast iron flywheel housing with dual positions for starter and type approved instrumentation in order to suit a variety of installations.

	Rating	Engine speed (rpm)		
		1200	1500	1800
Gross power, full load (kW)	ICFN	262	315	331
Gross power, full load (hp, metric)	ICFN	356	428	450
Gross power, propeller curve (kW)	ICFN	120	210	331
Gross power, propeller curve (hp, metric)	ICFN	163	285	450
Gross torque (Nm)	ICFN	2085	2003	1756
Spec fuel consumption. Full load (g/kWh)		193	190	195
Spec fuel consumption. 3/4 load (g/kWh)		192	191	196
Spec fuel consumption. 1/2 load (g/kWh)		196	197	206
Spec fuel consumption. Propeller curve (l/h)		28	48	77
Optimum fuel consumption (g/kWh)		191		
Reductant consumption. Full load (g/kWh)		21	21	21
Reductant consumption. Propeller curve (l/h)		1.6	3.5	5.2
Heat rejection to coolant (kW)		180	202	222

ICFN – Continuous service: Rated power available 1 h/1 h.
Unlimited h/year service time at a load factor of 100%

Standard equipment

- Scania Engine Management System, EMS
- Unit injectors, PDE
- Turbocharger
- Fuel pre-filter with water separator
- Fuel filter
- Oil filter, full flow
- Centrifugal oil cleaner
- Oil cooler, integrated in block
- Oil filler, in engine block
- Oil dipstick, in block
- Starter, 2-pole 7.0 kW
- Alternator, 2-pole 100A
- Flywheel SAE 14
- Silumin flywheel housing, SAE 1 flange
- Front-mounted engine brackets
- SCR-system
- Protection covers
- Closed crankcase ventilation

Engines with heat exchanger:

- Impeller sea water pump
- Heat exchanger with expansion tank

Optional equipment

- Hydraulic pump
- Side-mounted PTO
- Front-mounted PTO
- Exhaust connections
- Scania instrumentation 2.0
- Type approved instrumentation
- Engine heater
- Engine bracket with different heights
- Stiff rubber suspension
- Air cleaner
- Cast iron flywheel housing, SAE 1 flange
- Reversible fuel filter
- Low coolant level sensor
- Low and extra low oil sump
- Reversible oil filters
- Long oil dipstick
- Oil level sensor
- Reductant feed pump
- Bilge pump

Engines with heat exchanger:

- Self priming sea water pump

This specification may be revised without notice.

DI13 092M. 331 kW (450 hp)

IMO Tier III, EU Stage IIIA

Engine description

No of cylinders	6 in-line
Working principle	4-stroke
Firing order	1 - 5 - 3 - 6 - 2 - 4
Displacement	12.7 litres
Bore x stroke	130 x 160 mm
Compression ratio	17.3:1
Weight (excl oil and coolant)	1285 kg (Engine with heat exchanger) 1180 kg (Engine with keel cooling)
Piston speed at 1500 rpm	8.0 m/s
Piston speed at 1800 rpm	9.6 m/s
Camshaft	High position alloy steel
Pistons	Steel pistons
Connection rods	I-section press forgings of alloy steel
Crankshaft	Alloy steel with hardened and polished bearing surfaces
Oil capacity	28-34 dm ³ (standard oil sump)
Electrical system	2-pole 24V

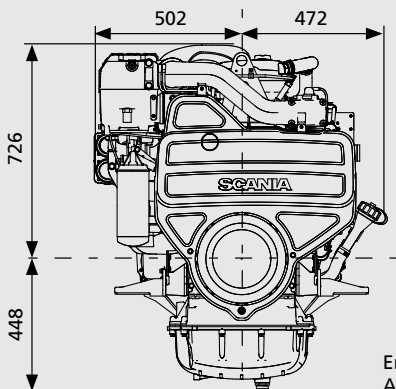
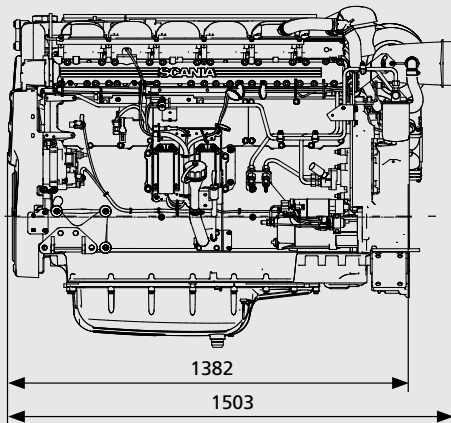

Engine with heat exchanger
All dimensions in mm

Output

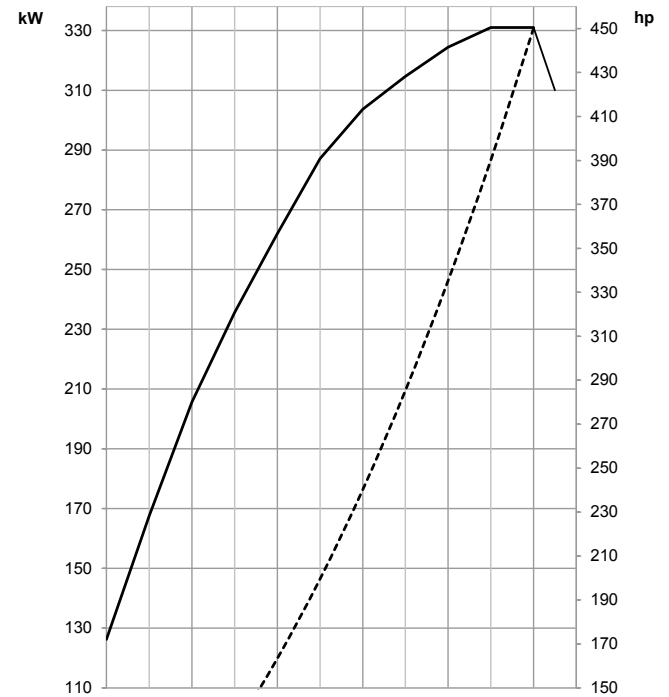

Torque

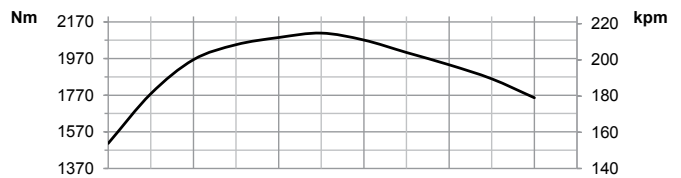

Spec reductant consumption

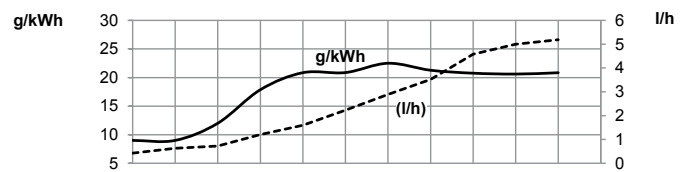

Spec fuel consumption

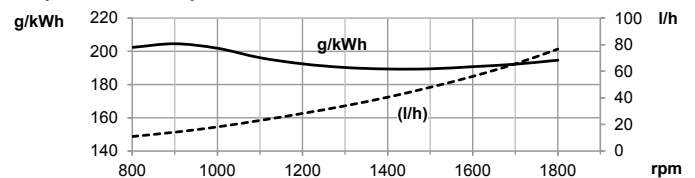

----- Propeller curve, assumed exponent 2.5
— Full load curve



SCANIA

SE 151 87 Södertälje, Sweden
Telephone +46 8 553 810 00
Telefax +46 8 553 829 93
www.scania.com
engines@scania.com



SCR system

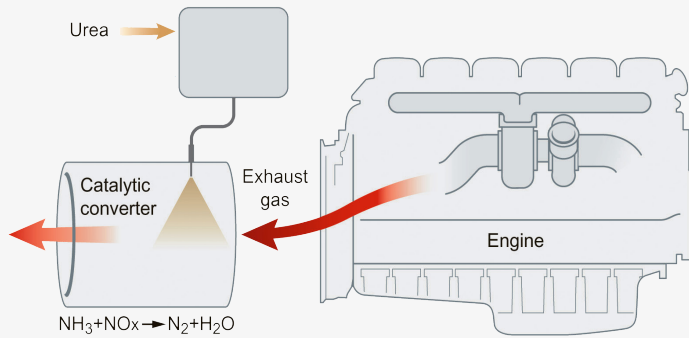

The principle for Scania SCR system

SCR (Selective Catalytic Reduction) technology is used on Scania's engines for IMO Tier III to reduce the NO_x content in the exhaust gases. A chemical process is started by injecting reductant, an urea and water mixture, into the exhaust gas stream. During injection the water evaporates and the urea breaks down to form ammonia. The ammonia then reacts with the nitrogen gases in the catalytic converter and forms harmless products such as nitrogen gas and water. Through the use of SCR the exhaust gases are purged of poisonous levels of NO_x in the best possible way. Scania is making use of a system that is carefully developed and tested in our own laboratory.

The Scania SCR system contains an exhaust routing valve that enables to by-pass the SCR system in order to meet the class requirements for marine installations. The system is delivered with an urea unit in stainless steel, prepared for connection to a main tank supported by customer. To ensure the flow of reductant between the main tank and the urea unit a reductant feed pump controlled by Scania can be included. The system can be offered with all mechanical and electrical parts needed except from the exhaust piping which is to be adapted according to the customers installation.

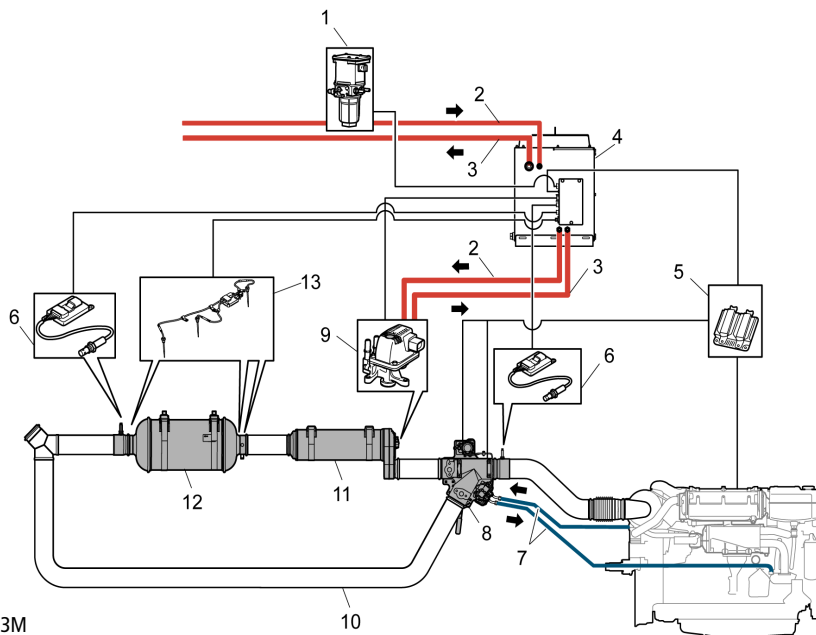

System overview DI13M

	Standard	Optional		Standard	Optional
1 Reductant feed pump	-	✓	8 Exhaust routing valve	✓	-
2 Reductant fluid pressure line	-	-	9 Reductant doser	✓	-
3 Reductant fluid return line	-	-	10 Branch pipe	-	-
4 Urea unit (including reductant tank, -pump, -pick up unit and control unit EEC)	✓	-	11 Evaporator module	✓	-
5 Control unit EMS	✓	-	12 SCR catalyst	✓	-
6 NO _x sensors	✓	-	13 Exhaust temperature sensors	✓	-
7 Coolant pipes	-	-			



SCR system

Urea unit

Total volume: 30 litres
Filling volume: 16 litres

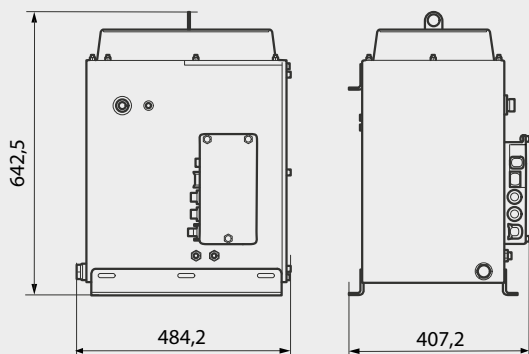

SCR catalyst

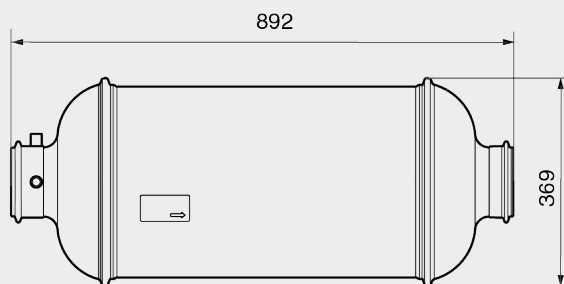

Evaporator module

