

# DC16 074A. 478 kW (650 hp)

China Phase II and Russia Stage I

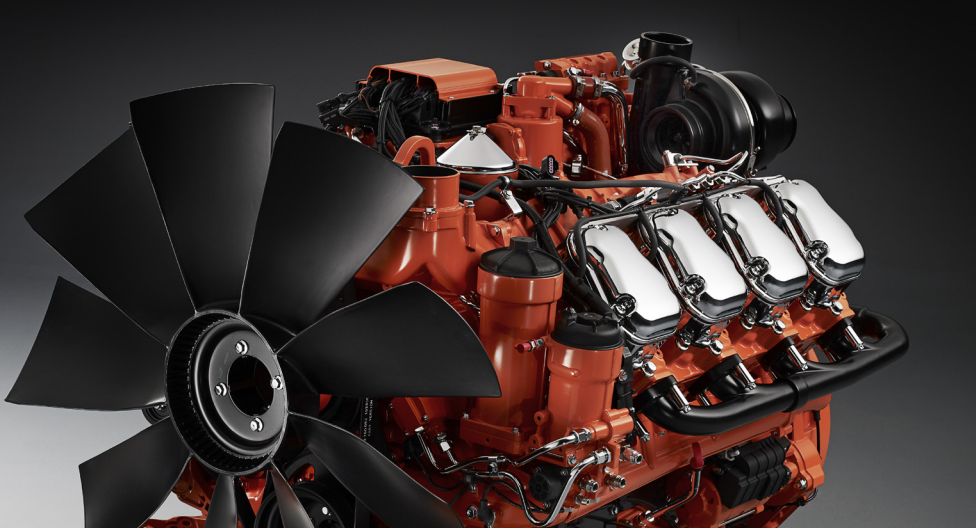

The industrial engines from Scania are based on a robust design with a strength-optimized cylinder block containing wet cylinder liners that can easily be exchanged. Individual cylinder heads with 4 valves per cylinder promotes reparability and fuel economy.

The engine is equipped with a Scania developed Engine Management System, EMS, to control of all aspects related to engine performance. The injection system is based on electronically controlled unit injectors that give low exhaust emissions with good fuel economy and a high torque. The engine can be fitted with many accessories such as air cleaners, silencers, PTOs and flywheels, to suit a variety of installations.

	Engine speed (rpm)			
	1200	1500	1800	2100
Gross power (kW)	356	478	478	478
Gross power (hp, metric)	484	650	650	650
Gross torque (Nm)	2830	3043	2536	2174
Spec fuel consumption at full load (g/kWh)	197	196	205	226
Spec fuel consumption at 3/4 load (g/kWh)	196	195	204	235
Spec fuel consumption at 1/2 load (g/kWh)	198	198	210	248
Heat rejection to coolant (kW)	164	165	185	219

**Rating: ICFN – Continuous service:** Rated output available 1/1 h. Unlimited h/year service time at a load factor of 100%

### Standard equipment

- Scania Engine Management System, EMS
- Unit injectors, PDE
- Turbocharger
- Saver ring in cylinder liner
- Fuel filter and extra pre-filter with water separator
- Oil filter, full flow
- Centrifugal oil cleaner
- Oil cooler, integrated in cylinder block
- Oil filler, in valve cover
- Deep front oil sump
- Oil dipstick, in cylinder block
- Magnetic drain plug for oil draining
- Starter motor, 1-pole 7.0 kW
- Alternator, 1-pole 100 A
- Flywheel, for use with friction clutch
- Silumin flywheel housing, SAE 1 flange
- Front-mounted engine suspension
- Open crankcase ventilation

### Optional equipment

- Cast iron flywheel housing
- Cooling package
- Prepared for cooling package
- Puller and pusher fans
- Fan ring with sealing
- Hydraulic pump
- Air compressor
- AC compressor
- Side-mounted PTO
- Front-mounted PTO
- Exhaust connections
- Engine heater
- Flywheel SAE14"
- Stiff rubber engine suspension
- Air cleaner
- Closed crankcase ventilation
- Studs in flywheel housing
- External thermostat for extra oil cooler
- Coolant level sensor
- Oil level sensor
- Low oil sump



# DC16 074A. 478 kW (650 hp)

## China Phase II and Russia Stage I

### Engine description

No of cylinders	90° V8
Working principle	4-stroke
Firing order	1 - 5 - 4 - 2 - 6 - 3 - 7 - 8
Displacement	16.4 litres
Bore x stroke	130 x 154 mm
Compression ratio	16.7:1
Weight	1340 kg (excl oil and coolant)
Piston speed at 1500 rpm	7.7 m/s
Piston speed at 1800 rpm	9.24 m/s
Camshaft	High position alloy steel
Pistons	Steel pistons
Connection rods	I-section press forgings of alloy steel
Crankshaft	Alloy steel with hardened and polished bearing surfaces
Oil capacity	35-45 dm <sup>3</sup>
Electrical system	1-pole 24 V

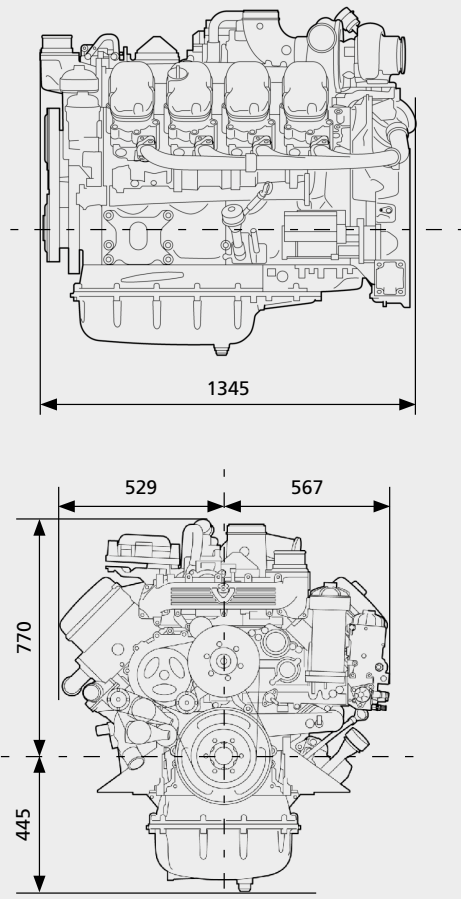

All dimensions in mm

### Output

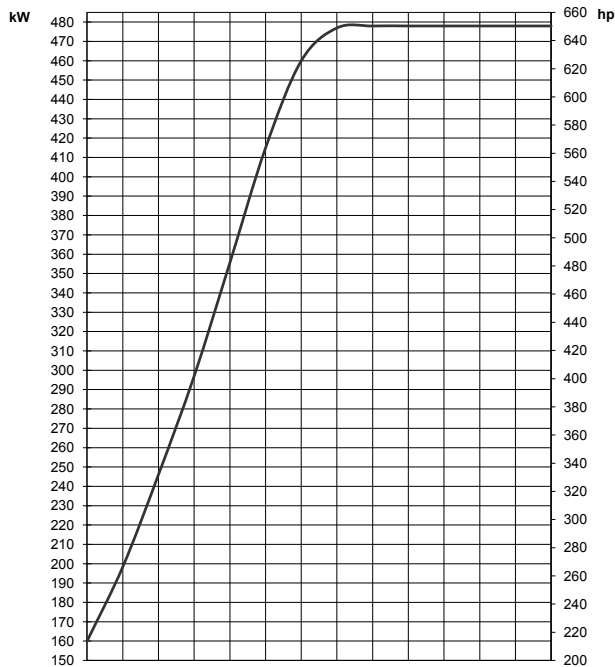

### Torque

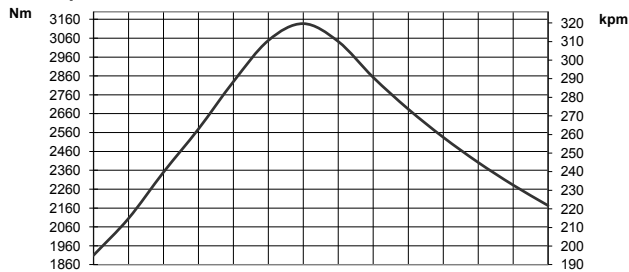

### Spec fuel consumption

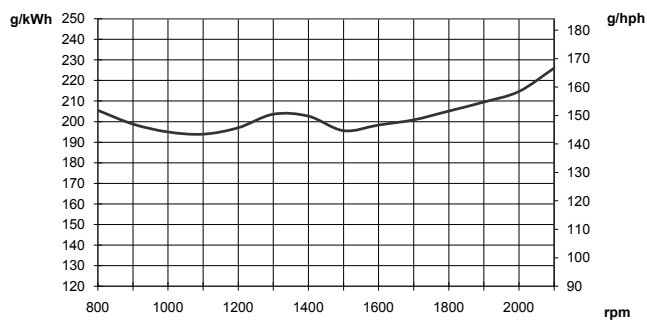

**Test conditions** Air temperature +25°C. Barometric pressure 100 kPa (750 mmHg). Humidity 30%. Diesel fuel acc. to ECE R 24 Annex 6. Density of fuel 0.840 kg/dm<sup>3</sup>. Viscosity of fuel 3.0 cSt at 40°C. Energy value 42700 kJ/kg. **Power test code** ISO 3046. Power and fuel values +/-3%.



SE 151 87 Södertälje, Sweden  
 Telephone +46 8 553 810 00  
 Telefax +46 8 553 829 93  
 www.scania.com  
 engines@scania.com