



SCANIA

Manual Radio Medium

**Complete manual for the Scania
Radio Medium**

This manual can be downloaded at www.scania.com/manuals

Overview



- (1) **Left multi-function button**
Volume control, ON/OFF button
Short press: Switch on Radio Medium
While in operation: Turn off sound (Mute)
Long press: Switch off Radio Medium
Turn: Adjust volume
- (2) **BND**
Short press: Select memory bank or waveband
Long press: Start Travelstore function
- (3) **Eject CD**
- (4) **CD compartment**
- (5) **Display**
- (6) **MENU**
Open main menu
- (7) **Right multi-function button. Browse menus.**
- (8) **AUD**
Open sound properties menu
- (9) **TA**
Activate/Deactivate traffic information priority
Cancel current traffic message
- (10) **Keypad 1 - 6, buttons change function according to what you are listening to**
- (11) **RDS**
Activate/Deactivate RDS function
- (12) **SRC**
Select audio choice: radio, AUX or CD (when CD is inserted), MP3 (when MP3 CD is inserted) and USB (when USB device is connected)

Contents

Manual	Radio Medium.....	1
	Complete manual for the Scania Radio Medium	1
Overview.....		2
Contents		3
About the manual		5
	Downloading the manual	5
	Warning notices	5
	Symbols used in the manual	5
	Operation	5
	Cleaning instructions	6
	Disposal	6
	Safety	6
	Caution!	6
Anti-theft protection		7
	Activating or deactivating anti-theft protection (CODE)	7
	Entering the code	8
Switching the Radio Medium on and off		9
	Switching the Radio Medium on and off with the ON/OFF button	9
	Steering wheel buttons	9
	Switching the Radio Medium on or off with the ignition key	9
	Switching the Radio Medium on and off by inserting a CD	9
	Setting auto shut-off timer	10
Setting the volume		11
	Pausing audio (MUTE)	11
	Using the MENU button	12
	Radio medium menu contents	13
	Activating/deactivating sound signal (BEEPTONE)	13
	Setting maximum start volume (ON VOLUME)	14
	Setting noise-dependent graduated audio level adjustment (GALA)	14
Changing sound properties.....		15
	Setting TREBLE	15
	Setting BASS	15
	Setting MIDDLE	15
	Volume balance left/right (BALANCE)	15
	Activating LOUDNESS	16
	STAGING	16
	Subwoofer and staging (accessories)	16
Radio		18
	Switching on the radio	18
	RDS functions (AF, REGION)	18
	Selecting waveband/memory bank	19
	Tuning into stations	19
	Storing stations	20
	Retrieving stored stations	20
	Scanning stored stations (PRSTSCAN)	20
		3

Scanning receivable stations (SCAN)	21
Programme type (PTY)	21
Noise adapted treble reduction (HICUT)	22
Activating/deactivating radio text (RDSTEXT)	22
Traffic information priority	23
Activating/deactivating traffic announcement priority	23
Setting volume regulation for traffic announcements	23
Switching off traffic announcements	24
CD mode	25
Starting CD mode	25
Selecting a track	25
Fast searching (audible)	26
Random track play (RND)	26
Scanning tracks (SCAN)	26
Repeating tracks (RPT)	26
Pausing playback (PAUSE)	26
Ejecting a CD	27
Listening to MP3/WMA	28
Preparing an MP3 CD	28
Starting MP3 mode	29
Display of track information (CD tags)	30
Selecting folders	30
Selecting tracks/files	31
Fastsearching	31
Random track play (RND)	31
Scanning tracks (SCAN)	31
Repeating single tracks or entire folders (RPT)	33
Pausing playback (PAUSE)	33
Using external audio sources (AUX).....	34
Starting AUX mode	34
Setting AUX input level	34
Restoring factory settings (RESET).....	35
Technical Specifications	36
Terminal diagram	37
Radio Equipment Directive 2014/53/EU (RED)	38

About the manual

This manual contains important information that will help you operate your Radio Medium simply and safely.

- Read carefully through the entire manual before using your Radio Medium.
- Store the manual in a place that is easily accessible for all users.
- If you pass on the Radio Medium to another person, make sure to also give them this manual.

Always remember to also follow the instructions for other equipment that you use in combination with this Radio Medium.

Downloading the manual

This is the complete manual for the Scania Radio Medium. It is available for downloading at www.scania.com/manuals

A summary of the most important functions is provided in the Driver's Manual for the vehicle.

Warning notices

The manual contains the following important warning notices:

Caution!

This caption is used when there is a risk of personal injury or damage to physical property.

Note

This caption is used for important items and information.

Symbols used in the manual

- Identifies an action to be performed.
 - Identifies a list.
- (1) - (12) Refers to the buttons and face of the Radio Medium.

Operation

This Radio Medium is intended for installation and use with 12 V.
Observe the performance limits listed in the Technical Specifications chapter.
Consult a professional to perform repairs, installation and removal as needed.

Cleaning instructions

Solvents, detergents and scouring agents such as dashboard spray or plastic cleaners may contain substances that could damage the surface of the Radio Medium.

Use only a dry or slightly dampened cloth to clean the Radio Medium.

Disposal

Do not throw electronic products out with the household waste!

Take the Radio Medium to a recycling centre for disposal.

Safety

This Radio Medium has been manufactured according the latest technological developments and in compliance of applicable technical safety regulations. Failure to observe the safety instructions in this manual could lead to damage or injury.

Caution!

The Radio Medium contains a Class 1 laser that could damage your eyes.

Do not open the Radio Medium and do not make any adjustments, connections or changes.

Protect your hearing by always keeping the volume at a moderate level.

When the truck is in motion:

- Only use the Radio Medium when traffic situations permit! Stop at a suitable place if you plan to make extensive setting adjustments.
- Adapt the volume so that you can hear warning signals (emergency vehicle sirens etc).

Anti-theft protection

The Radio Medium is equipped with anti-theft protection which is activated by a 4-digit code. This code ensures that the Radio Medium cannot be operated without the code if it has been removed from the vehicle. Whenever the Radio Medium has been disconnected from the battery, the code must be entered to operate the system again. The anti-theft protection is deactivated when it is delivered from the factory. You can activate the anti-theft protection by following the instructions below.

The code number is located in the radio pass supplied with the Radio Medium.

Note

Never keep the radio pass in the vehicle!

Activating or deactivating anti-theft protection (CODE)

- Press the **MENU** button (6).
- Press button **▲** or **▼** (7) (may need to press several times) until "CODE" is shown in the display (5).
- Press button **<** or **>** (7) once, to show "CODE" and the current setting, "ON" or "OFF".
- Press button **<** or **>** (7).

The display (5) will show "- - - -". Enter the code:

- Press the station button **1** (10) (may need to press several times) until the first digit in your code number appears in the display (5).
- Press the station button **2** (10) (may need to press several times) until the second digit in your code number appears in the display (5).
- Press the station button **3** (10) (may need to press several times) until the third digit in your code number appears in the display (5).
- Press the station button **4** (10) (may need to press several times) until the fourth digit in your code number appears in the display (5).
- When the correct code number is shown in the display (5), press and hold the station button **5** (10) for more than two seconds.

"CODE" will again appear in the display (5) along with the current setting, ON" or "OFF".

- Press button **<** or **>** (7) to deactivate/activate the anti-theft protection.
- Press button **▲** or **▼** (7) to adjust additional settings in the menu,
or
- press the **MENU** button (6), to save all settings and close the menu.

Note

If you have entered the code number incorrectly, "- - - -" will be shown in the display (5) again. You are given two more attempts to enter the code. After a third incorrect attempt, the anti-theft protection's activate/deactivate function will be locked for one hour and the Radio Medium will return to the menu, menu option "SLEEP." If you attempt to activate or deactivate the anti-theft protection during this waiting time, "WAIT 1H" will be shown in the display (5). If you turn off the Radio Medium during the waiting time, you will have to wait one full hour after switching it on again before you can enter the code.

Entering the code

You will need to enter the code if the vehicle's battery master switch has been switched off or if the power to the Radio Medium has been severed in any other way.

- Switch on the Radio Medium.

"CODE" will be shown first in the display (5) and then "- - -". You can now enter the code.

Note

If you have entered the code number incorrectly, "- - -" will be shown in the display (5) again. You will be given two more attempts to enter the code. After a third incorrect attempt to enter the code, the Radio Medium will lock down for an entire hour. During this hour, "WAIT 1H" will be shown in the display (5). If you switch on the Radio Medium during this waiting time, you will have to wait an entire hour after you have switched it on again before you can enter the code.

- Enter the code number according to the descriptions in the section "Activating or deactivating anti-theft protection (CODE)".
- When the correct code number is shown in the display (5), press and hold the station button **5** (10) for more than two seconds.

The Radio Medium will start.

Switching the Radio Medium on and off

You can switch the Radio Medium on or off in several different ways:

Switching the Radio Medium on and off with the ON/OFF button

- Press the ON/OFF button (1) to switch the Radio Medium on.
- When you wish to switch the Radio Medium off, press and hold down the left multi-function button (1) for more than two seconds.

Note

To protect the vehicle's battery, the Radio Medium will automatically switch off after the ignition has been off for a preset period of time (see section "Setting auto shut-off timer" in this chapter).

Steering wheel buttons

You can control the Radio Medium with the steering wheel buttons.

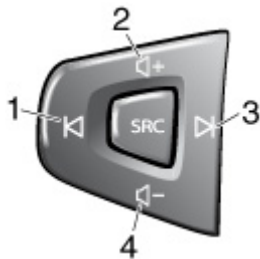

- 1 and 3: Change station or CD track.
- 2 and 4: Increase or decrease volume.
- SRC: Change audio source.

Switching the Radio Medium on or off with the ignition key

If the Radio Medium has not been switched off with the left multi-function button (1), it will switch on when the vehicle's ignition is turned on or off (provided, of course, that the Radio Medium is connected to the ignition).

Switching the Radio Medium on and off by inserting a CD

To switch the Radio Medium on by inserting a CD:

- Insert a CD with the printed side up in the drive and push it into the CD compartment (4) until you feel a slight resistance.

The CD will be pulled in automatically. The Radio Medium will start in CD mode.

Setting auto shut-off timer

- Press the **MENU** button (6).
- Press button **▲** or **▼** (7) (may need to press several times) until "SLEEP" appears in the display (5).
- Press button **<** or **>** once to show "SLEEP" and then the current setting (5 to 60 minutes in 5-minute increments).
- Press button once more **<** or **>**, to decrease or increase the time setting.
- Press button **▲** or **▼** (7) to adjust additional settings in the menu,
or
- press the **MENU** button (6), to save all settings and close the menu.

Setting the volume

The volume of the Radio Medium can be set in increments from 0 (off) to 32 (max).

- To increase system volume, turn the volume control (1) to the right.
- To decrease system volume, turn the volume control (1) to the left.

Pausing audio (MUTE)

You can turn off system sound completely by pressing MUTE.

- Press and release the left multi-function button (1).

Resetting sound level

To return to the set volume before muting:

- Press and release left multi-function button (1).

Using the MENU button

Press the MENU button (6) to open the Radio Medium main menu. You can change Radio Medium settings in the menu. Use the up and down arrows on the rocker button to browse through the menu. Use the right and left arrows to select options. When you are satisfied with your selection, press the down arrow to come to the next menu line or press MENU to save the setting(s) and exit the menu.

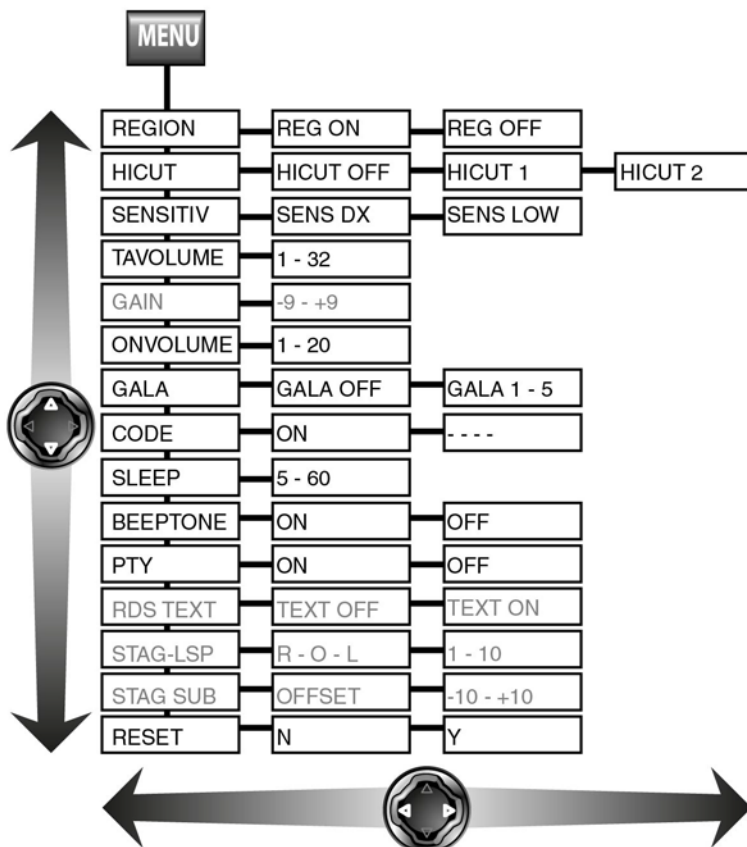

Use Rocker Buttons **▲** or **▼** (7) to navigate the Radio Medium menu.

Radio medium menu contents

- REGION: Off - On. The radio will select local stations. RDS must be activated.
- HICUT: OFF - 1. 2. Regulates radio static.
- SENSITIV: DX - LO. Sensitive. Regulates radio sensitivity when searching for radio stations. DX: radio searches for all receivable stations. LO (local): radio searches for stations with strongest signals.
- TAVOLUME: 1-32. Volume of traffic announcements in relation to basic volume.
- GAIN: -9 - +9. Adjusts input volume from an external audio source.
- ONVOLUME. Volume when switched on.
- GALA. Noise and speed adapted volume control.
- CODE. Anti-theft protection.
- SLEEP. Amount of time the Radio Medium will remain active without power.
- BEEPTONE. Beeptone, warning signal on or off.
- PTY. Searches for stations with programme information.
- RDSTEXT. Shows radio station RDS information in display. Displayed only if RDS is activated.
- RESET

Activating/deactivating sound signal (BEEPTONE)

A signal (beep) will sound when:

- Press and hold down a station button to store a station.
- The maximum temperature in the CD player is exceeded.
- A faulty CD is detected.
- No station broadcasting traffic information is in reach when traffic information priority is activated.

To turn off the sound signal:

- Press the **MENU** button (6).
- Press button **▲** or **▼** (7) (may need to press several times) until "BEEPTONE" is shown in the display (5).
- Press button **<** or **>** (7) once, to show the current setting, "BEEP ON" or "BEEP OFF".
- Press button **<** or **>** (7) again, to switch between settings.
- Press button **▲** or **▼** (7) to adjust additional settings in the menu,
or
- press the **MENU** button (6), to save all settings and close the menu.

Setting maximum start volume (ON VOLUME)

When you turn on the Radio Medium, playback will start at the volume last selected. However, if you select a higher volume than the maximum start volume before you turn off the radio, the volume will automatically be limited to the pre-set maximum start volume the next time you turn on the radio.

- Press the **MENU** button (6).
- Press button **▲** or **▼** (7) (may need to press several times) until "ONVOLUME" is shown in the display (5).
- Press button **<** or **>** (7) once, to display "ONVOL" and the current setting (1 - 20).
- Press the button once more **<** or **>** (7), to raise or lower the volume.
- Press button **▲** or **▼** (7) to adjust additional settings in the menu,
or
- press the **MENU** button (6), to save all settings and close the menu.

Setting noise-dependent graduated audio level adjustment (GALA)

This function automatically adapts the audio volume to the driving speed and accompanying truck sounds. For example, the volume is increased automatically at increased speeds to compensate for the increase in noise (e.g. from headwind or engine).

GALA only functions if the Radio Medium is correctly connected to the instrument cluster. The automatic volume regulation setting has 6 levels: OFF, 1 (low) - 5 (high).

- Press the **MENU** button (6).
- Press button **▲** or **▼** (7) (may need to press several times) until "GALA" is shown in the display (5).
- Press button **<** or **>** (7) once, to display "GALA" and the current setting.
- Press button **<** or **>** (7) again, to select the desired setting.
- Press button **▲** or **▼** (7) to adjust additional settings in the menu,
or
- press the **MENU** button (6), to save all settings and close the menu.

Changing sound properties

Setting TREBLE

- Press button **AUD** (8).
- Press button **▲** or **▼** (7) (may need to press several times) until "TREBLE" appears in the display (5).
- Press button **<** or **>** (7) once, to display "TREB" and the current setting.
- Press button **<** or **>** (7) again, to set treble from -7 to +7.
- Press button **▲** or **▼** (7) to adjust additional settings in the menu,
or
- press the **AUD** button (8), to save all settings and close the menu.

Setting BASS

- Press button **AUD** (8).
- Press button **▲** or **▼** (7) (may need to press several times) until "BASS" appears in the display (5).
- Press button **<** or **>** (7) once, to display "BASS" and the current setting.
- Press button **<** or **>** (7) again, to set bass level from -7 to +7.
- Press button **▲** or **▼** (7) to adjust additional settings in the menu,
or
- press the **AUD** button (8), to save all settings and close the menu.

Setting MIDDLE

- Press button **AUD** (8).
- Press button **▲** or **▼** (7) (may need to press several times) until "MIDDLE" appears in the display (5).
- Press button **<** or **>** (7) once, to display "MID" and the current setting.
- Press button **<** or **>** (7) again, to set middle level from -7 to +7.
- Press button **▲** or **▼** (7) to adjust additional settings in the menu,
or
- press the **AUD** button (8), to save all settings and close the menu.

Volume balance left/right (BALANCE)

- Press button **AUD** (8).
- Press button **▲** or **▼** (7) (may need to press several times) until "BALANCE" is shown in the display (5).
- Press button **<** or **>** (7) once, to display "BAL" and the current setting.
- Press button **<** or **>** (7) again, to set volume balance left/right from -10 to +10.
- Press button **▲** or **▼** (7) to adjust additional settings in the menu,
or
- press the **AUD** button (8), to save all settings and close the menu.

Activating LOUDNESS

Loudness increases the volume on treble and base frequencies and improves sound, particularly at low volumes.

- Press button **AUD** (8).

Menu option "LOUDNESS" is displayed.

- Press button **<** or **>** (7) once, to show the current setting, "LD ON" or "LD OFF".
- Press button **<** or **>** (7) again to switch between settings.
- Press button **▲** or **▼** (7) to adjust additional settings in the menu,
or
- press the **AUD** button (8), to save all settings and close the menu.

STAGING

STAGING is used to artificially "change" the positioning of the speakers so that the driver or passenger seat seems to be positioned directly between the left and right speaker. This evens out the various distances between your location in the truck and the locations of the right and left speakers.

Staging operates by delaying certain sound signals. When you set staging, audio playback will be slightly delayed in certain speakers. This makes these speakers seem to be farther away.

For example, you sit on the left-hand seat in the truck closer to the left speaker and hear sounds from the left speaker slightly earlier than from the other speakers. This means that you perceive the sound to come from the left, since you hear it first from that direction. If the sound in the left speaker is delayed slightly, the sounds will reach your ears at the same time from the left and right speakers and it will seem as though you are sitting directly between the speakers.

You can set the delay for either the right or left speaker and thereby optimize the audio experience for either the driver or the passenger. Staging is factory-set for left-hand driven vehicles. If your vehicle is right-hand driven, we recommend this setting be adjusted according to the instructions below.

Subwoofer and staging (accessories)

You can also "move" the subwoofer (perceived location of base frequencies) forwards or backwards in the direction of travel according to the same principles.

Activating/deactivating STAGING

- Press button **AUD** (8).
- Press button **▲** or **▼** (7) (may need to press several times) until "STAGING" is shown in the display (5).
- Press button **<** or **>** (7) once to show the current setting, "STAG ON" or "STAG OFF".
- Press button **<** or **>** (7) again to switch between settings.
- Press button **▲** or **▼** (7) to adjust additional settings in the menu,
or

- press the **AUD** button (8), to save all settings and close the menu.

Optimizing staging for driver or passenger seat (STAG-LSP)

Available settings:

- 0: No staging
- L01 - L12: Slight to large delay for left speaker (optimization for left seat)
- R01 - R12: Slight to large delay for right speaker (optimization for right seat)

Note

This setting option is only available when staging is activated.

To set staging for driver and passenger seats,

- press the **MENU** button (6).
- Press button **▲** or **▼** (7) (may need to press several times) until "STAG-LSP" appears in the display (5).
- Press button **<** or **>** (7) once, to display "STAG" and the current setting.
- Press button **<** or **>** (7) again, to select the desired setting.
- Press button **▲** or **▼** (7) to adjust additional settings in the menu,
or
- press the **MENU** button (6), to save all settings and close the menu.

Optimization of staging for subwoofer (STAG-SUB) (accessory)

This setting requires a correctly installed subwoofer.

Available settings, -9 till +9:

- 0: No subwoofer offset.
- +1 till +9: Virtual forward offset of subwoofer.
- -1 till -9: Virtual backward offset of subwoofer.

Note

This setting option is only available when staging is activated.

To set staging for the subwoofer,

- press the **MENU** button(6).
- Press button **▲** or **▼** (7) (may need to press several times) until "STAG-SUB" is shown in the display (5).
- Press button **<** or **>** (7) once, to display "OFFSET" and the current setting.
- Press button **<** or **>** (7) again, to select the desired setting.
- Press button **▲** or **▼** (7) to adjust additional settings in the menu,
or
- press the **MENU** button (6), to save all settings and close the menu.

Radio

The radio is equipped with an RDS radio receiver. In addition to the programme itself, many FM radio stations also transmit signals containing information such as the station name and programme type (PTY).

If the RDS station transmits its name, it will be shown directly in the display (5).

Switching on the radio

If you are listening to another audio source:

➤ press the **BND** button (2)

or

➤ press the **SRC** button (12) (may need to press several times) until "RADIO" is shown in the display (5).

The current frequency and station name will appear in the display (5).

RDS functions (AF, REGION)

RDS functions AF (alternative frequency) and REGION (regional) increase radio capabilities.

- **AF:** When the RDS function is activated, the radio will automatically tune in to the best receivable frequency for the current station.
- **REGION:** Some stations periodically divide their programmes into regional programmes with different content. The activated REGION function prevents the radio from changing to alternative frequencies that are broadcasting different programme content.

Note

REGION must be activated and deactivated separately in the menu.

Switching the RDS function ON/OFF

➤ To use the RDS functions AF and REG, press the **RDS** button (11).

The RDS function is activated when the RDS symbol appears in the display (5).

REGION ON/OFF

➤ Press the **MENU** button (6).

Menu option "REGION" is displayed.

➤ Press button **<** or **>** (7) once, to show the current setting, "REG ON" or "REG OFF".

➤ Press button **<** or **>** (7) again to switch between settings.

➤ Press button **^** or **v** (7) to adjust additional settings in the menu,

or

➤ press the **MENU** button (6), to save all settings and close the menu.

Note!

The REG ON/OFF setting will only work if the RDS function is activated.

Selecting waveband/memory bank

The radio can receive stations broadcast on FM, MW and LW bands. There are three memory banks available for FM (FM1, FM2 and FMT) and one each for MW and LW (AM broadcast) bands. Each memory bank can store up to six stations.

To switch between wavebands and memory banks:

- Press the **BND** button (2)

Tuning into stations

You can tune into stations in various ways:

Automatic search for stations

- Press button **<** or **>** (7).

The nearest station within the receivable area will be selected.

Note!

- If traffic information priority is activated, the radio will tune into the nearest station broadcasting traffic information.
"TP-SEEK" will be shown in the display (5) during the search.
- If PTY is activated, the radio will tune into the closest station broadcasting the selected programme type.
"PTY-SEEK" will be shown in the display (5) during the search.

Setting sensitivity for station search

You can adjust radio "sensitivity" to search for the strongest stations or all receivable stations. SENS LO (local): the radio searches for the strongest stations. SENS DX: the radio searches for all stations.

- Press the **MENU** button (6).
- Press button **▲** or **▼** (7) (may need to press several times) until "SENSITIV" appears in the display (5).
- Press button **<** or **>** (7) once to show the current setting "SENS LO" (the strongest) or "SENS DX" (search all) in the display (5).
- Press button **<** or **>** (7) again to switch between settings.
- Press button **▲** or **▼** (7) to adjust additional settings in the menu,
or
- press the **MENU** button (6), to save all settings and close the menu.

Manual tuning

To change the set frequency in small increments,

- press button **▲** or **▼** (7).

Note

Manual tuning is only possible when PTY is deactivated.

Storing stations

Storing stations manually

- Select the desired memory bank and waveband.
- Tune into the station.
- Press one of the station buttons **1 - 6** (10) to assign the station to that button. Hold for more than two seconds.

The beep signal will sound. The station is now stored on the selected station button.

Storing stations automatically (Travel-STORE, only FM)

You can automatically store the six strongest FM stations in the region. The stations will be stored in the FMT memory bank.

Note

Stations previously stored on the FMT level will be replaced by the new stations.

- Select desired waveband.
- Press and hold down the **BND** (2) button for more than two seconds.

The storing process will begin. "T-STORE" will be shown in the display (5). When the process has completed, the station will play on memory location 1 of the FMT memory bank.

Retrieving stored stations

- Select the memory bank and waveband.
- Press the station button **1 - 6** (10) where the desired station is stored.

Scanning stored stations (PRSTSCAN)

The PRSTSCAN function allows you to scan all stations stored on a storage level. Each station will play for approximately 10 seconds.

Starting scan

- Select memory bank.
- Press and hold down the **▲** or **▼** (7) button for more than two seconds.

The display will briefly show "PRSTSCAN" and will then flash "P" while scanning. The radio will scan stations stored on the current memory bank for about 10 seconds each. The frequency and station name will be displayed at the same time.

Cancelling scan

- Press button **▲** or **▼** (7).

The current station will continue to play.

Scanning receivable stations (SCAN)

You can use the scan function to listen to all of the receivable stations in the area for approximately 10 seconds per station.

Starting scan

- Press and hold down the < or > (7) button for more than two seconds.

"SCAN" will be shown briefly on the display. The radio will search for stations within the current waveband. The current memory bank will flash during the scan. Each station found will be played for about 10 seconds. The frequency and station name will be displayed at the same time.

Cancelling scan

- Press button < or > (7).

The current station will continue to play.

Programme type (PTY)

In addition to broadcasting the programme itself, some FM stations also transmit inaudible information on the programme content and type. Examples of programme types include CULTURE, TRAVEL, JAZZ, SPORT, NEWS, POP, ROCK or MUSIC. The PTY function can help you select stations broadcasting a particular type of programme.

When PTY is activated and a PTY search has commenced, the radio will automatically switch from the current station or from another audio source to the station with the selected programme type.

Using PTY

- Press the **MENU** button (6).
- Press button **▲** or **▼** (7) (may need to press several times) until "PTY" appears in the display (5).
- Press button < or > once, to show the current setting, "PTY ON" or "PTY OFF".
- Press button < or > again, to switch between settings.
- Press button **▲** or **▼** (7) to adjust additional settings in the menu,
or
- press the **MENU** button (6), to save all settings and close the menu.

Selecting programme type and starting search

- Press button **▲** or **▼** (7) (may need to press several times) until the desired programme type is displayed.
- Press button < or > (7) to start the search.

"PTY-SEEK" will be shown briefly in the display and the search will start. If a station matching the selected programme type is found, the radio will switch to that station. If no station is found, the radio will return to the latest station played.

Noise adapted treble reduction (HICUT)

The HICUT function improves sound quality during poor radio reception. If interference occurs, HICUT will automatically reduce any static or noise.

To activate/deactivate and adjust HICUT settings,

- press the **MENU** button (6).
- Press button **▲** or **▼** (7) (may need to press several times) until "HICUT" appears in the display (5).
- Press button **<** or **>** (7) once to show the current setting "HICUT OFF", "HICUT 1" or "HICUT 2" (size of HICUT noise level reduction).
- Press button **<** or **>** (7) again to switch between settings.
- Press button **▲** or **▼** (7) to adjust additional settings in the menu,
or
- press the **MENU** button (6), to save all settings and close the menu.

Activating/deactivating radio text (RDSTEXT)

Some radio stations use the RDS signal to transmit advertisements or other information instead of the station name. This radio text will be shown in the display (5). You can choose to either activate or deactivate radio text display.

Note

This setting is only available when the RDS function is activated.

- Press the **MENU** button (6).
- Press button **▲** or **▼** (7) (may need to press several times) until "RDSTEXT" appears in the display (5).
- Press button **<** or **>** (7) once, to show the current setting, "TEXT ON" or "TEXT OFF".
- Press button **<** or **>** (7) again to switch between settings.
- Press button **▲** or **▼** (7) to adjust additional settings in the menu,
or
- press the **MENU** button (6), to save all settings and close the menu.

Traffic information priority

Activating/deactivating traffic announcement priority

To activate or deactivate traffic information priority while in any audio source mode:

- press button **TA** (9).

Traffic announcement priority is activated when the TA symbol is shown in the display (5). As soon as the radio receives a traffic announcement, it will be played. "TRAFFIC" will be shown in the display (5) while the announcement is played.

Note!

- If you leave the broadcast area of a station broadcasting traffic information whilst listening, or change to a station that is not broadcasting traffic information, "NO TP" will appear briefly in the display (5) and a warning beep will sound. If this happens, you can either deactivate traffic announcement priority or tune into another station broadcasting traffic information.
- If you have used the volume control to set the volume to "0" whilst listening to the radio and then leave the broadcasting area for the previously selected traffic information station, the radio will automatically start searching for another station broadcasting traffic information. If no such station is found, "NO TP" will appear briefly in the display (5), a warning beep will sound and the radio will return to the last selected station.
- If you leave the broadcasting area for a previously selected traffic information station whilst listening to another audio source (a CD, for example), the radio will automatically start a search for another station broadcasting traffic information.

Setting volume regulation for traffic announcements

You can set the volume for all audio sources, including traffic messages, from 1 to 32.

- Press the **MENU** button (6).
 - Press button **▲** or **▼** (7) (may need to press several times) until "TAVOLUME" appears in the display (5).
 - Press button **<** or **>** (7) once, to display "TAVOL" and the current setting (1-32).
 - Press button **<** or **>** (7) again, to set volume regulation from 1 to 32.
 - Press button **▲** or **▼** (7) to adjust additional settings in the menu,
- or
- press the **MENU** button (6), to save all settings and close the menu.

Note

You can use the volume control (1) to adjust the volume during a traffic announcement for the duration of that announcement. When the announcement is over, volume will return to the previous setting.

Switching off traffic announcements

To switch off a traffic announcement in progress and return to the audio source you were listening to before,

➤ press button **TA** (9).

Traffic announcement priority is still activated.

CD mode

You can use the CD drive to play standard audio CDs and writable discs (CD-Rs, CD-RWs) with a diameter of 12 cm. To ensure the device functions properly, you should not burn CDs of speeds greater than 16x.

Caution!

Risk of severe damage to the CD player!

- Do not use 8 mm CDs (Mini CDs) or contoured CDs (Shape CDs).
 - Handle the CD carefully and avoid scratching or otherwise damaging it. Only handle CDs on the edges whenever possible. To clean dirty CDs, use a lint-free cloth without solvent. Always wipe CDs from the centre outwards.
 - Keep CDs out of direct sunlight and store in a case/sleeve when not in use.
 - Do not affix any labels to CDs. Use a suitable felt pen to write on CDs.
 - Scania does not accept responsibility for damage to the CD player caused by unsuitable or damaged CDs.
-

For optimal performance, only use CDs with the Compact Disc logo. Copy-protected CDs may not play correctly. Scania cannot guarantee that the device will function properly when playing copy-protected CDs!

Note

If the ambient Radio Medium temperature exceeds 70 degrees Celsius, some of the Radio Medium functions will switch off. "OVERTEMP" and "CDOFF" will be shown in the display. When the temperature falls below 70 degrees Celsius, you can resume using the CD player and other functions as usual.

Starting CD mode

If there is no CD inserted in the drive:

- insert a CD (printed side up) in the drive and press it into the CD compartment until you feel some resistance.

The CD will automatically be pulled into the drive. The CD symbol will appear in the display (5).

Note

Do not touch the Radio Medium whilst it draws in the CD.

The CD will begin to play. The number and playing time of the first track ("T01") will be shown in the display (5).

If there is already a CD in the player,

- press the **SRC** button (12) (may need to press several times) until "CD" appears in the display (5).

Playback will begin from the point at which it was last interrupted.

Selecting a track

- Press button < or > (7) to select previous or next track.

To restart the current track from the beginning, press button < (7) once.

Fast searching (audible)

To quickly search forwards or backwards,

- press and hold down < or > (7) until you reach the place you are looking for.

Random track play (RND)

- Press button 3 (10).

"RND CD" will be shown briefly in the display (5). The following tracks will be selected randomly.

Cancelling RND

- Press button 3 (10) again.

"RND OFF" will be shown briefly in the display (5) and the RND symbol will disappear. Playback will then continue as usual.

Scanning tracks (SCAN)

To scan all the tracks on a CD for 10 seconds each,

- press button 4 (10).

"SCAN TRK" will be shown briefly in the display. "CD" will blink in the display during scanning. The number and playing time of the current track will be shown.

Cancelling scan

- Press button 4 (10) again.

"SCAN OFF" will be shown briefly in the display. The current track will continue to play.

Repeating tracks (RPT)

- Press button 2 (10).

"RPT TRK" will be shown briefly in the display and the RPT symbol will appear. The current track will repeat until the RPT function is deactivated.

Cancelling RPT

- Press button 2 (10) again.

"RPT OFF" will appear briefly in the display (5) and the RPT symbol will disappear. Playback will then continue as usual.

Pausing playback (PAUSE)

- Press button 1 (10).

"PAUSE" will be shown in the display (5).

Resuming playback

- With pause activated, press button **1** (10).

Playback will resume.

Ejecting a CD

Note

It is possible to eject CDs even when the Radio Medium is switched off or while another audio source is activated.

- Press button (3) to eject the CD.

The CD is ejected. "CD EJECT" will appear briefly in the display.

Note

Do not touch the Radio Medium whilst the CD is ejecting!

- Remove the CD

The CD symbol will disappear.

Note

If you do not remove the ejected CD, it will be automatically drawn back in after approx. 20 seconds.

Listening to MP3/WMA

You can also use this Radio Medium to listen to CD-Rs and CD-RWs containing MP3 and WMA music files. You can also connect a USB device (accessory) to a USB interface and play MP3/WMA files saved on the USB device.

As MP3 and WMA files are handled in the same way, this chapter only discusses how to play MP3 files. In this chapter, the designation "MP3 storage device" refers to both CD-R/RWs and to USB devices (USB flash drives).

Note!

- WMA music files equipped with Digital Rights Management (DRM, digital copy protection) from online music services cannot be played in this Radio Medium.
- Playback of WMA files can only be guaranteed if they have been created with Windows Media Player, version 8.

Preparing an MP3 CD

Preparing an MP3 CD

The various combinations of CD burners, CD burning software and writable CD products may impair the device's ability to play certain CDs. If you experience problems playing burned CDs, you should consider switching to another brand or colour of blank CD.

CD format must correspond to ISO 9660 Level 1/Level 2 or Joliet. Other formats cannot be played reliably.

When you create (code) MP3/WMA files from audio files, you should use a bitrate of between 32 and 320 kbps for MP3 files and a bitrate between 32 and 192 for WMA files.

The CD drive supports up to 252 folders and up to 255 files per folder. A CD may contain a maximum of 512 folders and files. Folders and CD tracks can be selected and played separately.

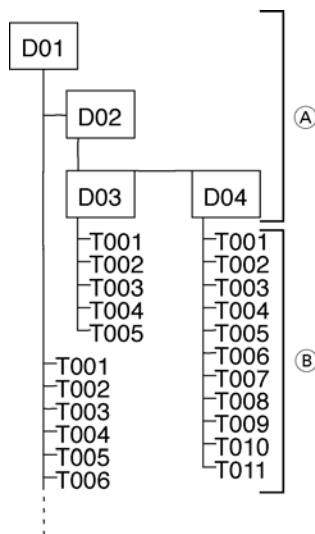

- A Folders
- B Tracks · Files

You can use your computer to name folders and tracks/files before you burn the CD. The file name for a track is shown in the display when the track starts playing (provided no ID3 tags have been saved for the track). Each folder and each track/file can be named in the computer with your CD burning software. Consult the software manual or contact the manufacturer for more information.

Note!

- Avoid using special accents or characters (such as å, é, ç) when you name folders and tracks/files.
- Using file names with more than 16 characters (applies to ".mp3" and ".wma") will reduce the maximum number of tracks and folders permitted.

If it is important for you that your files be in a certain order, use your burning software to save the files in the order that you would like them to play. The Radio Medium will play the files in the order that you have saved them on the storage device. To play files on the Radio Medium, MP3 files must end in ".mp3" and WMA files must end in ".wma".

Note!

To ensure uninterrupted playback:

- Do not attempt to add ".mp3" to files that are not actual MP3 files and then try to play them. These files are invalid and will be ignored during playback.
- Do not use "mixed" CDs combining MP3 files and non-MP3 files (the Radio Medium will only read MP3 files during playback).
- Do not use mix-mode CDs containing CD audio tracks and MP3 tracks. If you try to play a mix-mode CD, the system will only play the audio tracks.

Preparing a USB device (accessory)

In order for the Radio Medium to recognize the USB device, it must be designated as a Mass Storage Device, be formatted in either the FAT16 or FAT32 file system and contain MP3 or WMA files.

You can create up to 1,500 files (folders and tracks) on a USB device. Folders and tracks can be selected separately with this Radio Medium. Using file names with more than 24 characters (applies to ".mp3" and ".wma") will reduce the maximum number of files permitted.

Scania cannot guarantee that all USB devices on the market will function properly when used with this Radio Medium.

ID3 tags

MP3 tracks may contain extra information such as artist, title and album (ID3 tags). The Radio Medium can show version 1 and 2 ID3 tags in the display.

Starting MP3 mode

Starting MP3 playback from CD

You activate a CD with MP3 files in the same way as a regular audio track CD (.cda). For more information, see the section entitled "Starting CD mode" in the "CD mode" chapter.

"READING" may appear first in the display (5), if the CD data is being read but audio playback is not yet possible.

The number of the current folder (e.g. "DIR 02") will then be displayed briefly, followed by track information for the current track (ID3 tags or file name). During playback, the current track number (e.g. "T12") and the playing time will be displayed.

When switching to another folder, the folder number (e.g. "DIR 02" for MP3 CDs) or the folder name (for USB) will appear briefly.

Connecting USB devices and playing MP3 files (accessory)

To be able to connect a USB device (e.g. a USB flash drive or a USB hard disk), you must connect a USB interface (accessory) to the AUX input at the back of the Radio Medium (Group C3). The USB interface cable can then be stored in the glove box or the centre console.

Note

Always switch the Radio Medium off before you connect or disconnect the USB device so that the device is always registered or stopped correctly.

- Connecting USB devices to the USB interface via the USB cable.

As soon as the USB device is connected, it can be selected by pressing the **SRC** button (12). "USB" will appear in the display. Information on the current folder and track (see section "Starting MP3 playback from CD" will then be shown.

Display of track information (CD tags)

If the MP3 storage device shows ID3 tags, track information (only track name) will appear briefly as running text in the display (5) when the track starts. If no ID3 tags have been saved with the MP3 files, the file name will be shown instead.

Note

Refer to your CD burning software manual for more information about saving ID3 tags.

Activating/deactivating permanent display of track information

To activate or deactivate permanent display of track information,

- press **5** (10).

"SCRL ON" or "SCRL OFF" will appear briefly in the display (5). When activated, track information will be shown permanently in the display (5) instead of track number and playing time.

Note

Permanent display of track information will only be active until you cancel MP3 mode or select another track or another folder.

Selecting folders

To move upwards or downwards to another folder,

- press button **▲** or **▼** (7).

Note!

- The Radio Medium will ignore all folders that do not contain MP3 files.

- The Radio Medium will handle all folders and sub-folders as if they were on the same level. You can also open all sub-folders by repeatedly pressing button **▲** or **▼** (7).

Selecting tracks/files

To move upwards or downwards to another track,

- press button **<** or **>** (7).

To restart the current track from the beginning, press button **<** (7) once.

Fastsearching

To quickly search forwards or backwards:

- Press and hold down **<** or **>** (7) until you reach the part of the track you are looking for.

Note

When fast searching on a USB device, playback will begin from the beginning of the track even if you search backwards.

Random track play (RND)

To play tracks in the current folder in random order:

- Press button **3** (10) (may need to press several times) until "RND DIR" (for MP3 CDs) or "RND FLD" (when using USB, accessory) is shown in the display (5).

The RND symbol will appear in the display (5).

If you would like to play all of the tracks on the MP3 storage device in random order,

- press button **3** (10) (may need to press several times) until "RND ALL" appears in the display (5).

The RND symbol will appear in the display (5).

Cancelling RND

To cancel random play,

- Press button **3** (10) (may need to press several times) until "RND OFF" appears in the display (5).

The RND symbol will disappear from the display (5).

Scanning tracks (SCAN)

To scan all tracks on an MP3 storage device in ascending order for approx. 10 seconds each,

- briefly press button **4** (10).

"SCAN TRK" will appear briefly in the display (5).

To scan all tracks in the current folder,

- press and hold down button **4** (10) for more than two seconds.

"SCAN FLD" will appear briefly in the display (5). "MP3" or "USB" will blink in the display during scanning.

Cancelling scan

To cancel scanning,

- briefly press button **4** (10).

"SCAN OFF" will appear briefly in the display (5). The current track will continue to play.

Repeating single tracks or entire folders (RPT)

To repeat the current track,

- press button **2** (10) (may need to press several times) until "RPT TRK" appears in the display (5).

The RPT symbol will appear in the display (5).

To repeat the current folder,

- press button **2** (10) (may need to press several times) until "RPT DIR" (for MP3 CDs) or "RPT FLD" (for USB) appears in the display (5).

The RPT symbol will appear in the display (5).

Cancelling REPEAT

To cancel repeat mode,

- press button **2** (10) (may need to press several times) until "RPT OFF" appears in the display (5).

The RPT symbol will then disappear from the display (5).

Pausing playback (PAUSE)

- Press button **1** (10).

"PAUSE" will be shown in the display (5).

Resuming playback

- With pause activated, press button **1** (10).

Playback will resume.

Using external audio sources (AUX)

If no USB interface is connected to the Radio Medium, you can connect another external audio source, such as a portable CD player, Mini-Disc player or MP3 player to the AUX input (Group C3 on the back of the Radio Medium).

Note

To connect an external audio source, you will need the correct adapter cable. Contact your Scania Workshop for more information.

Starting AUX mode

- Press the **SRC** button (12) (may need to press several times) until "AUX" appears in the display (5).

Note!

- You can even select AUX mode when no external audio source is connected.
- AUX mode is not available if a USB device is connected via a USB interface with C'n'C-function.(Command and Control)

Setting AUX input level

You can adapt the level on the external audio source to the level on the Radio Medium's own audio sources (such as CD and radio).

Note

This setting is only available in AUX mode.

- Press the **SRC** button (12) as needed (may need to press several times) until "AUX" appears in the display (5).
- Press the **MENU** button (6).
- Press button **▲** or **▼** (7) (may need to press several times) until "GAIN" appears.
- Press button **◀** or **▶** (7) once, to display "GAIN" and the current setting.
- Press button **◀** or **▶** (7) again, to set level from -9 to +9.
- Press button **▲** or **▼** (7) to adjust additional settings in the menu,
or
- press the **MENU** button (6), to save all settings and close the menu.

Restoring factory settings (RESET)

It is possible to restore the Radio Medium settings to factory settings.

- Press the **MENU** button (6).
- Press button **▲** or **▼** (7) (may need to press several times) until "RESET" appears in the display (5).
- Press button **<** or **>** (7).

"RESET N" appears.

- Press button **>** (7) to restore factory settings.

"RESET Y" appears. The factory settings are restored.

- Press button **▲** or **▼** (7) to adjust additional settings in the menu,
or
- press the **MENU** button (6), to save all settings and close the menu.

Technical Specifications

Operating voltage	+12 V
Max. power consumption	approx. 7.5 A
Standby power consumption	approx. 1 MA
Output power	4 x 20 Watt at 14.4 V, THAD=10 % $R_{LP} \geq 4 \Omega$
Input sensitivity AUX	2 V / 600 Ω
Wavebands	
FM	87.5 - 108 MHz
MW	531 - 1602 kHz
LW	153 - 279 kHz
FM frequency response	30 - 15,000 Hz
CD frequency response	20 - 20,000 Hz
Temperature range	-20 to +70 °C
Weight	approx. 1.3 kg
Dimensions (installation) W x H x D (mm)	approx. 180 x 50 x 160
Subject to changes!	

Terminal diagram

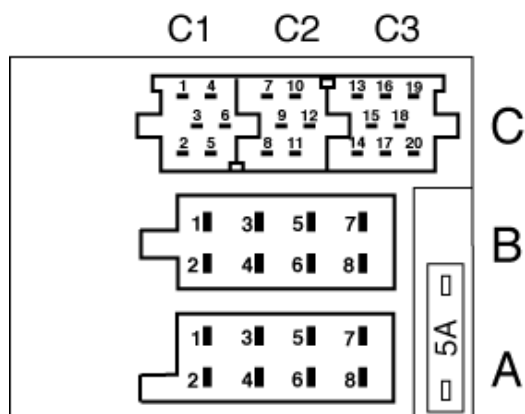

Connector location	Terminal	Function
A	1	CAN_High
	2	CAN_Low
	3	n.c.
	4	Ignition plint 15
	5	Ignition_D (wake up)
	6	n.c.
	7	Battery (12 V)
	8	Ground / MINUS
B	1	Tweeter Right Front (+)
	2	Tweeter Right Front) (-)
	3	Woofers Right Front (+)
	4	Woofers Right Front (-)
	5	Woofers Left Front (+)
	6	Woofers Left Front (-)
	7	Tweeter Left Front (+)
	8	Tweeter Left Front (-)
C1	1	n.c.
	2	n.c.
	3	n.c.
	4	n.c.
	5	n.c.
	6	Phone Mute
C2	7	PHONE IN AF+
	8	PHONE IN AF-
	9	Subwoofer GND
	10	Subwoofer Out
	11	n.c.
	12	n.c.
C3	13	PeriPort Data In
	14	PeriPort Data Out
	15	Switched Power Supply 12V (for accessories PeriPort)
	16	PeriPort Wakeup
	17	GND PeriPort
	18	PeriPort AF/AUX AF-GND
	19	PeriPort AF/AUX AF-IN LEFT
	20	PeriPort AF/AUX AF-IN RIGHT

Radio Equipment Directive 2014/53/EU (RED)

Robert Bosch Car Multimedia GmbH hereby declares that this product is in compliance with Directive 1999/5/EC and/or 2014/53/EU. The complete text of the EU Declaration of Conformity is available at the internet address below.

The safety notices applicable to the device can be found in the device's operating instructions. The device's operating instructions and Declaration of Conformity can be downloaded from <http://cert.bosch-carmultimedia.net> or accompany this information.