



INTRODUCING THE NEW SCANIA V8 RANGE

WHEN EMOTION MEETS LOGIC

SCANIA



Updated with a unique dark grey V8 grille and a new chromed front roof trim.



CREATING IMAGE WITH STYLE

When you drive a Scania V8, you are driving a premium truck with a premium engine. And that should be visible too. It's part of the unique driving experience that only a V8 can create. Where a driver with high demands not only gets built-in quality and outstanding power, but also a distinctive way of expressing it.

The Scania V8 range offers an exclusive V8 styling package. Where both the exterior and interior have various design features and options. Including the V8 truck in its characteristic red colour.

It gives you the opportunity to make a personal statement. Just the way you want it.

THE LEADER IN SUSTAINABLE TRANSPORT

The world urgently needs to break the link between increasing demand for transport and increasing carbon emissions, noise, congestion and road accidents.

The new Scania V8 engine has improved energy efficiency with lower fuel consumption. This translates to lower emissions per transported ton.

All of our Euro 6 engines in the V8 range can run on renewable HVO fuel and Biodiesel.

Driving a Scania V8 has always been a reason for pride and the starting point for an experience filled with emotions. But the V8 engine is so much more than just a feeling. It's a logically superior decision that makes sense for your business as a whole.

The new Scania V8 engine is two pieces of a puzzle, perfectly matched. Where amazing driveability co-exists with outstanding performance and fuel efficiency. And where the legendary engine sound reveals incomparable power and robustness.

This is our way of proving that you can have it both ways. That it's possible to get an incredible driving experience that also drives your business.

Because the new Scania V8 range is where emotion meets logic.

FOR THE HEAVIEST LOADS & TOUGHEST ROADS

A V8 FOR EVERY OPERATION – FIND YOUR MATCH

There are many components that have been updated and optimised in the new V8 engine:

- New exhaust gas aftertreatment concept with twin dosing
- New high pressure fuel pump
- New engine management system
- Optimised 180A alternator
- Increased compression ratio
- Increased peak cylinder pressure
- Reduced internal friction
- Fixed geometry turbo
- Single bank exhaust manifold
- Dis-engageable air compressor
- Variable steering pump
- Ball bearing turbo charger
- Rocker covers with V8 styling



Lower weight - More Load

When adding more power and torque we have been able to reduce the weight by 75kg. The weight reductions will benefit payload and energy efficiency.

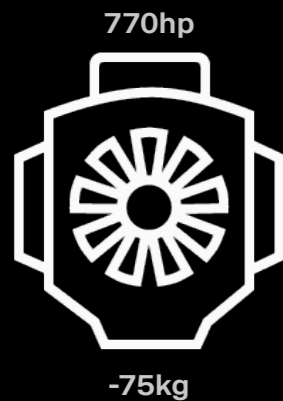

POWER/TORQUE

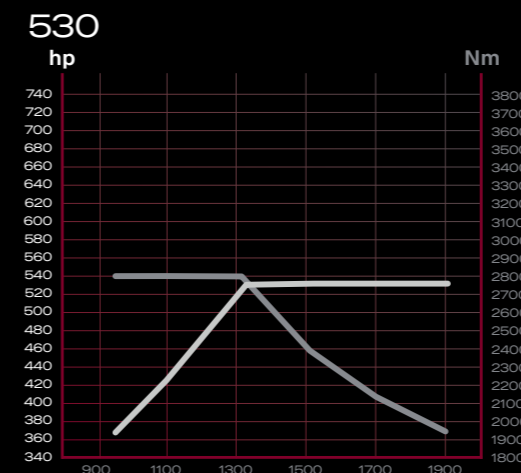

Cylinders: V8
Swept volume: 16,4 litres
Max. power: 530 hp (390 kW) at 1900 r/min
Max. torque: 2800 Nm at 925-1325 r/min
Emission control: SCR
Turbo: FGT
Camshaft: Normal
Renewable fuel: HVO

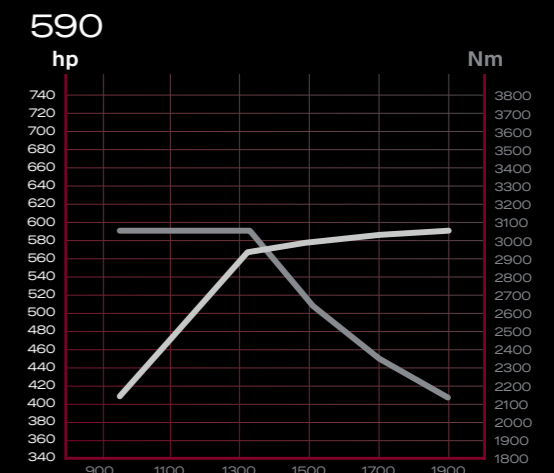

Cylinders: V8
Swept volume: 16,4 litres
Max. power: 590 hp (434 kW) at 1900 r/min
Max. torque: 3050 Nm at 925-1350 r/min
Emission control: SCR
Turbo: FGT
Camshaft: Normal
Renewable fuels: HVO, Biodiesel

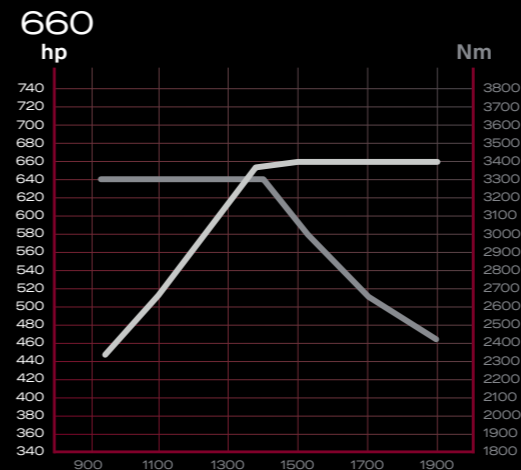

Cylinders: V8
Swept volume: 16,4 litres
Max. power: 660 hp (485 kW) at 1900 r/min
Max. torque: 3300 Nm at 950-1400 r/min
Emission control: SCR
Turbo: FGT
Camshaft: Normal
Renewable fuel: HVO

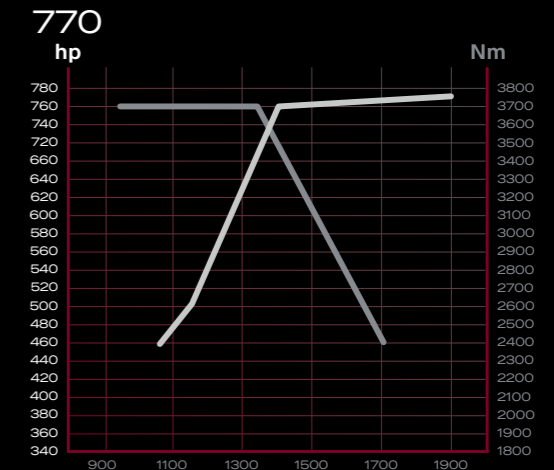

Cylinders: V8
Swept volume: 16,4 litres
Max. power: 770 hp (566 kW) at 1800 r/min
Max. torque: 3700 Nm at 1000-1450 r/min
Emission control: SCR
Turbo: FGT, water cooled ball bearing
Camshaft: Normal
Renewable fuel: HVO

A NEW INDUSTRY BENCHMARK

A superior engine needs premium gearshifting. Scania's new Opticruise G33CM gearbox features improved and rapid gearshifting in combination with better fuel economy and excellent comfort.

After six years of development and testing we are introducing a gearbox with a lot of new technologies, such as variable oil volume, improved gear lubrication by oil spray function and with a wider gear spread.

Thanks to significantly reduced internal losses the gearbox itself offers fuel savings of 1 %.

The new Scania Opticruise gearbox is available for all V8 engines up to 660 hp.

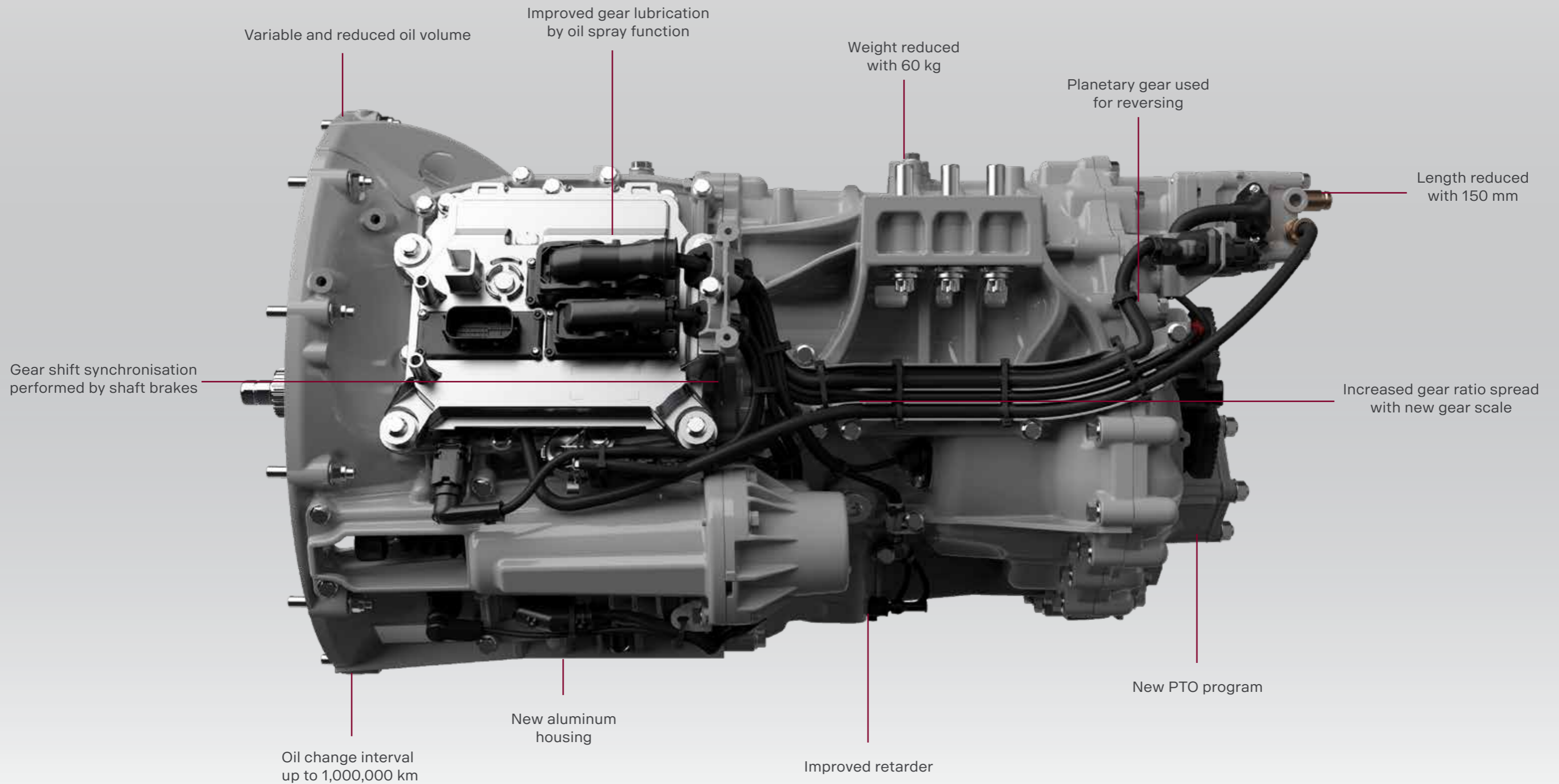

UP TO 6% FUEL SAVINGS

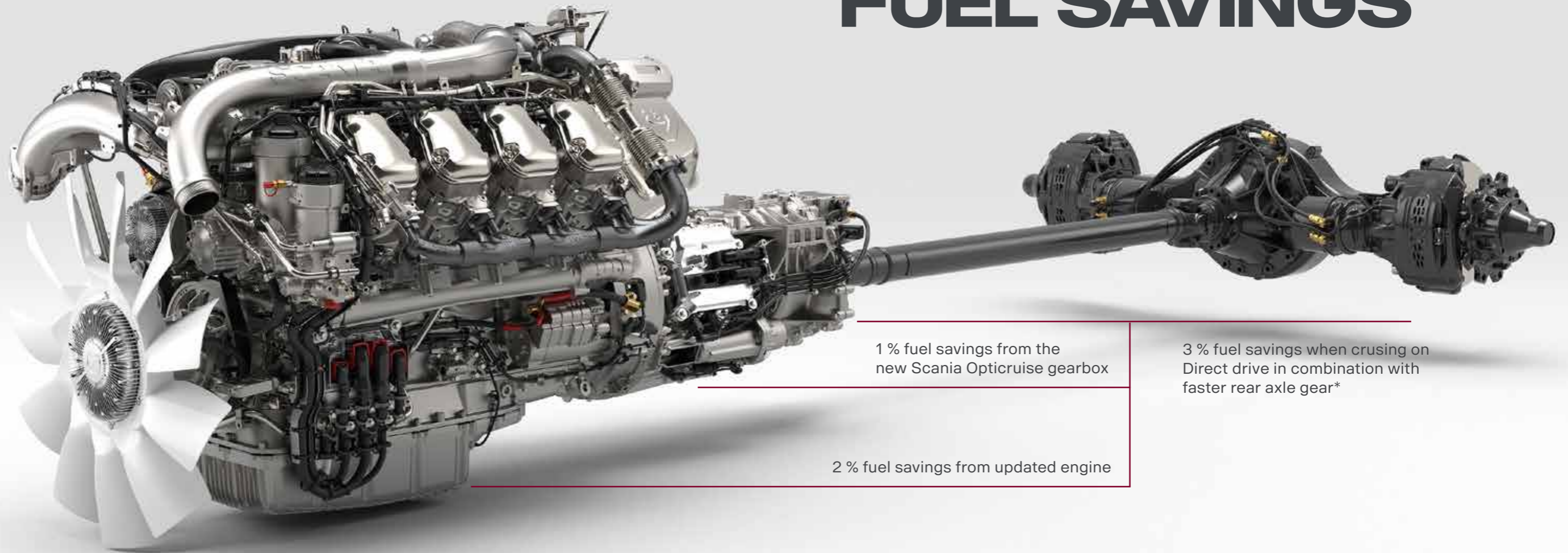

1 % fuel savings from the new Scania Opticruise gearbox

3 % fuel savings when cruising on Direct drive in combination with faster rear axle gear*

2 % fuel savings from updated engine

OPTIMISED FOR OUTSTANDING PERFORMANCE

We decided to improve our premium offer because we had the means to do so. And we didn't compromise. With our market-leading expertise in powertrain development, we designed a technically advanced solution with impressive operating economy that delivers more power already at low revs.

The new V8 powertrain with a rear axle gear adapted for cruising on Direct drive (gear 12) can give up to six percent in fuel savings. As an example, a 590 hp truck in long haulage operations in a hilly topography can achieve savings in this range.

This will be a true leader in the segment and the new industry benchmark. It's the perfect fit for operations in need of the efficiency, power and performance that only a Scania V8 powertrain can deliver. Allowing you to focus on what is really important – your business.

*580 hp/GRSO/3,08 vs 590 hp/G33CM/2,59

For more information contact your
Scania branch or local dealer.

HEAD OFFICE

212 – 216 Northbourne Rd
Campbellfield, 3061
Tel: (03) 9217 3300

VICTORIA

Scania Campbellfield
212 – 216 Northbourne Rd
Campbellfield, 3061
Tel: (03) 9217 3300

Scania Dandenong

2/66 Greens Rd
Dandenong South, 3175
Tel: (03) 9217 3600

Scania Laverton

125 – 129 Boundary Rd
Laverton, 3026
Tel: (03) 9369 8666

NEW SOUTH WALES

Scania Prestons

16 – 18 Lyn Pde
Prestons, 2170
Tel: (02) 9825 7900

Midcoast Trucks

Lot 1 Pacific Highway
Boambee, 2450
Tel: (02) 6652 7218

QUEENSLAND

Scania Richlands

149 Archerfield Rd
Richlands, 4077
Tel: (07) 3712 8500

Scania Pinkenba

213 Holt St
Pinkenba, 4008
Tel: (07) 3712 7900

SOUTH AUSTRALIA

Scania Wingfield

218 – 234 Cormack Rd
Wingfield, 5010
Tel: (08) 8406 0200

WESTERN AUSTRALIA

Scania Kewdale

527 – 529 Abernethy Rd
Kewdale, 6105
Tel: (08) 9360 8500