

SCANIA STREAMLINE

**G 440/480**  
**8X4 RIGID**  
Chassis Specification



**SCANIA**  
Total Transport Solutions  
scania.com.au



## G-SERIES

Scania G-series trucks are the prime choice for all-round performance in a broad array of applications.

Scania's G 440/480 8x4 Rigid trucks are the perfect base on which to build a reliable, rugged and durable heavy tipper or mining support vehicle

# G 440/480

## 8X4 RIGID

### Chassis Specification

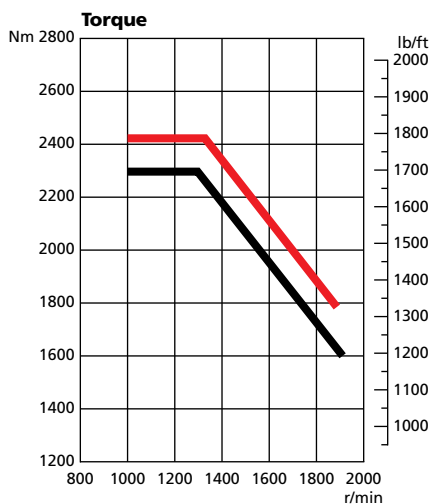
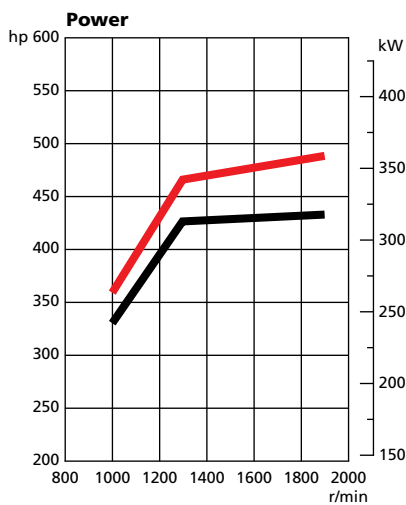

— G 480  
— G 440

### Engine

- **Scania DC 13 480** 12.7 Litre In-line 6 cylinder engine
- Power - 480hp (353kW) @1900rpm
- Torque - 2400Nm (1700lb/ft) @1000 - 1350rpm
- Exhaust brake - 263kW @ 2400rpm
- Emission - Euro5 (ADR 80/03)
- **Scania DC 13 440** 12.7 Litre In-line 6 cylinder engine
- Power - 440hp (324kW) @1900rpm
- Torque - 2300Nm (1696lb/ft) @1000 - 1350rpm
- Exhaust brake - 263kW @ 2400rpm
- Emission - Euro5 (ADR 80/03)

### Engine Features

- Scania electronic fuel injection
- Single stage turbocharger
- SCR with catalytic converter
- Centrifugal engine oil filter
- Spin-on turbocharger oil filter
- Cartridge style fuel filters

### Fan

- 11 Blade, electronically controlled viscous drive

### Alternator

- Scania 24V, 100amp

### Compressor

- Knorr 720, twin cylinder, 800L/min with air drier

### Air Cleaner

- Mounted under the grille R/H side

### Gearbox

- Scania GRSO905R, Overdrive 14 speed
- With Scania Retarder

### Gearbox Features

- Scania Opticruise with fully automatic clutch
- Gearbox oil cooler
- PTO - Electrical Preparation
- R4100D retarder

### Front & Rear Axles

#### Front Axle

- Scania AMA 740

#### Front Suspension

- Scania air bag suspension 14200kg capacity with anti roll bar

#### Rear Axles

- Scania ADA 1303 Axle housings
- Scania RB662/R660 Differentials
- Ratio 3.42 with power divider and differential locks

#### Rear Suspension

- Scania 4 bag air suspension (19000kg capacity)

#### Brakes

- Scania electronically controlled disc brakes
- EBS with integrated ABS and Traction Control
- Hill hold

#### Wheels

- Steel disc painted silver
- 22.5" x 8.25" Tubeless rims
- 335mm PCD

#### Tyres

- Front - Bridgestone 295/80 R22.5
- Rear - Bridgestone 295/80 R22.5

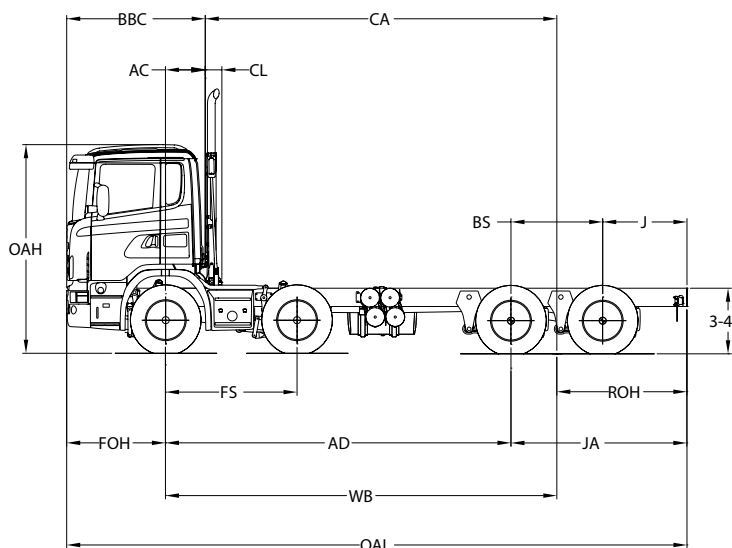

FOH	1455mm	CL	220mm
AD	5100mm	AC	588mm
WB	5775mm	3-4	997-969mm
FS	1940mm	OAL	9155mm
BS	1350mm	J	1250mm
ROH	1925mm	JA	2600mm
BBC	2043mm	OAH	3047mm
CA	5187mm		

Tare Weight: Front = 6960kg, Rear = 2685kg, Total = 9645kg.

Tare weight includes, tanks full of fuel. It does not include bull bar or driver.

Tare weight may vary +/- 5% depending on vehicle specifications.

\* Depend on chassis height and tyre size.

## Chassis

### Frame

- Scania F950, 270 x 90 x 9.5 mm
- External width 770 mm starting 2055mm behind first front axle

### Paint

- Scania Sub-Grey (Powder Coat)

### Axle Distance

- 5100mm (5775mm wheel base)
- Rear overhang 1925mm

### Fuel

- 400L (1x400L R/H)
- 1x75L Urea tank R/H

### Front Bumper

- High Mounted FUP compliant bumper
- FUP to ECE R93

### Batteries

- 24V (2x12V, 180amp) L/H Side
- Chassis electrical connection for auxiliary equipment (Max 200 amps)

### Trailer Connections - Brakes

- Trailer Supply & Emergency to end of frame

### Trailer Connections - Electrical

- 24V trailer light outlet (ISO 1185) to end of frame
- 24V trailer 7pin ABS outlet to end of frame
- Scania Body Work System with Cable Harness
- Front Mudguards with Spray suppression 1st axle only

## Cabin

- Scania CP16 day cab with four point spring suspension
- Cab Strength to ECE R29

### Paint

- Cabin painted Scania white
- With Brilliant Silver grille

### Exterior Equipment

- Aerodynamic main & spotter mirrors electrically heated
- Electrically adjustable main mirrors
- Close up mirror on passenger side
- Roof rails with full air foil kit
- Roof mounted air horns
- Manual central locking
- Reverse alarm

### Lighting

- H7 headlights
- End outline marker - White LED
- Identification lamp - Amber LED
- Boarding step lights

### Safety

- Drivers seat belt pretensioner
- Driver air bag

## Interior Equipment

- Medium driver's seat with armrests
- Folding passenger seat
- Black woven trim
- Cruise control and dash display controlled from the steering wheel
- Scania colour dash display featuring rear axle load, hour meter, service and vehicle information
- AM/FM radio, CD player
- AUX MP3, input
- Phone electrical preparation
- 12V outlet in dash
- FMS Preparation
- Resettable circuit breakers
- Power windows
- Manual climate control with air conditioning
- Protective rubber floor mats
- UHF CB radio

## Additional Equipment

- 20m tyre inflation hose
- Jack & wheel brace
- Globe kit
- Drivers manual
- Three safety triangles

## Notes



**SCANIA**  
Total Transport Solutions  
scania.com.au

### HEAD OFFICE

212 – 216  
Northbourne Rd  
Campbellfield, 3061  
Tel: (03) 9217 3300

### VICTORIA

**Scania Campbellfield**  
212 – 216 Northbourne Rd  
Campbellfield, 3061  
Tel: (03) 9217 3300

### Scania Dandenong

2/66 Greens Rd  
Dandenong South, 3175  
Tel: (03) 9217 3600

### Scania Laverton

125 – 129 Boundary Rd  
Laverton, 3026  
Tel: (03) 9369 8666

### NEW SOUTH WALES

**Scania Prestons**  
16 – 18 Lyn Pde  
Prestons, 2170  
Tel: (02) 9825 7900

### Scania Newcastle

1 Enterprise Drive  
Beresfield, 2322  
Tel: (02) 9825 7940

### K & J Trucks Pty Ltd

Lot 1 Pacific Highway  
Boambee, 2450  
Tel: (02) 6652 7218

### NJ's of Wagga

301 Copland Street  
Wagga Wagga, 2650  
Tel: (02) 6971 7214

### QUEENSLAND

**Scania Richlands**  
149 Archerfield Rd  
Richlands, 4077  
Tel: (07) 3712 8500

### Scania Pinkenba

213 Holt St  
Pinkenba, 4008  
Tel: (07) 3712 7900

### SOUTH AUSTRALIA

**Scania Wingfield**  
218 – 234 Cormack Rd  
Wingfield, 5010  
Tel: (08) 8406 0200

### WESTERN AUSTRALIA

**Scania Kewdale**  
527 – 529 Abernethy Rd  
Kewdale, 6105  
Tel: (08) 9360 8500

### Scania Bunbury

12 Proffitt St  
Davenport, 6230  
Tel: (08) 9724 6200