

SCANIA STREAMLINE

R 480
6X4 PRIME MOVER
Chassis Specification



SCANIA
Total Transport Solutions
scania.com.au



R-SERIES

Distinct, dynamic and sharper than ever, the new Scania R-series sets a new standard in long-haulage truck design and technology.

Scania's R 480 brings cutting edge Euro 5 compliant SCR technology and economy with genuine B-Double or heavy single trailer capacity. Ideal for interstate and long haul work.

R 480

6X4 PRIME MOVER

Chassis Specification

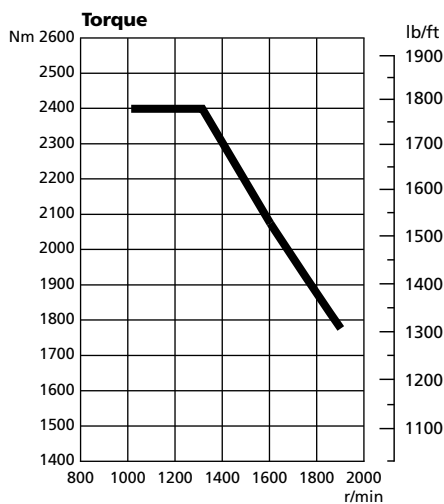
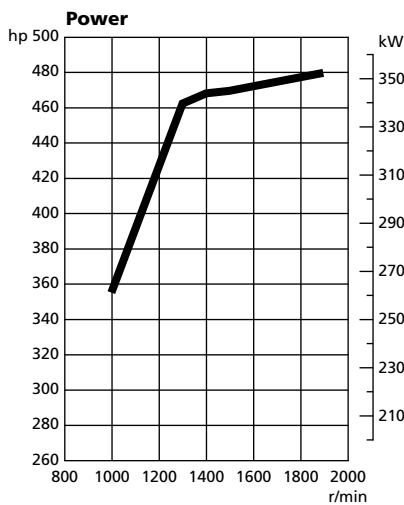

Engine

- Scania DC 13 480 12.7 Litre In-line 6 cylinder
- Power - 480hp (353kW) @ 1900rpm
- Torque - 2400Nm (1770lb-ft) @ 1000 - 1300rpm
- Euro 5 (ADR 80/03)

Engine Features

- Scania electronic fuel injection
- Single stage turbocharger
- SCR with catalytic converter
- Centrifugal engine oil filter
- Spin-on turbocharger oil filter
- Cartridge style fuel filter

Fan

- 11 Blade, electronically controlled viscous drive

Alternator

- Scania 24V, 100amp

Compressor

- Knorr 720, twin cylinder, 800L/min with air drier

Air Cleaner

- Mounted under the grille, RH side

Gearbox

- Scania GRS0905R, Overdrive 14 speed
- Scania Retarder

Gearbox Features

- Scania Opticruise
- Gearbox oil cooler
- PTO - Electrical Preparation
- R4100D Retarder

Front & Rear Axles

Front Axle

- Scania AM 740

Front Suspension

- 3 x 29 parabolic front springs 7500kg capacity with anti roll bar

Rear Axles

- Scania ADA 1100 Axle housing
- Scania RB662/R660 Differentials
- Ratio 3.42 with power divider and differential locks

Brakes

- Scania electronically controlled disc brakes
- EBS with integrated ABS and Traction Control
- Hill hold
- ESP

Wheels

- Alcoa aluminium disc polished, 22.5" x 8.25" tubeless rims
- 335mm PCD

Tyres

- Front - Bridgestone 295/80 R22.5
- Rear - Bridgestone 295/80 R22.5

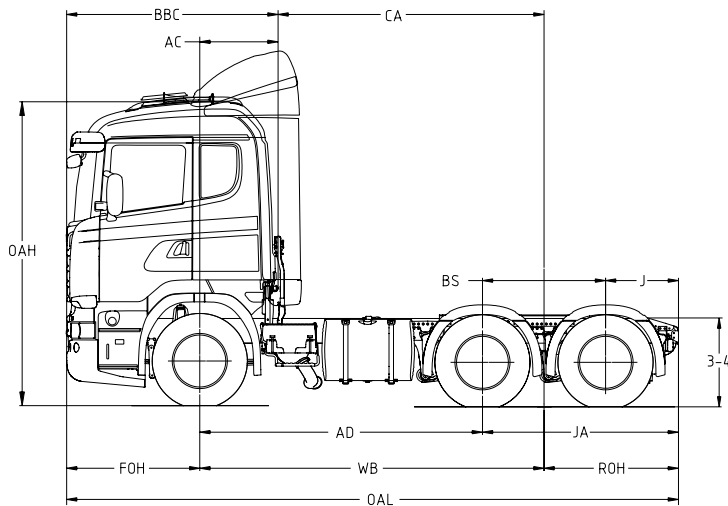

FOH	1460mm	AC	858mm
AD	3100mm	3-4	997-977mm
WB	3775mm	OAL	6710mm
BS	1350mm	J	800mm
ROH	1475mm	JA	2150mm
BBC	2318mm	OAH	3385mm
CA	2917mm	CL	255mm

Turntable mounting angles protrude 40mm above the chassis height.

Tare Weight: Front = 5480kg, Rear = 3455kg, Total = 8935kg.

Tare weight includes tanks full of fuel.

It does not include turntable, bullbar or driver.

Tare weight may vary +/- 5% depending on vehicle specifications.

Chassis

Frame

- Scania F950, 270 x 90 x 9.5mm
- Width 770mm

Paint

- Scania Sub-Grey (Powder Coat)

Axle Distance

- 3100mm (3775mm wheel base)
- Rear overhang 1475mm

Fuel Tanks

- 700L (1x400L L/H, 1x300L R/H)
- 1 x 75L Urea tank R/H

Front Bumper

- Low Mounted FUP compliant bumper
- FUP to ECE R93

Batteries

- 24V (2x12V, 180amp) L/H Side
- Chassis electrical connection for auxiliary equipment (Max 200amps)

Trailer Connections - Brakes

- Trailer Supply & Emergency suzi coils

Trailer Connections - Electrical

- 24V trailer light outlet (ISO 1185)
- Trailer lead 7pole to 7pole
- 24V trailer 7pin ABS outlet
- Scania Body Work System with Cable Harness
- Front Mudguards with Spray suppression
- Rear Mudguards with Spray suppression

Cabin

- Scania CR19 Normal Height Sleeper cab with four point spring suspension
- Cab Strength to ECE R29

Paint

- Cabin painted Scania white
- With Brilliant Silver grille

Exterior Equipment

- Aerodynamic main & spotter mirrors electrically heated
- Electrically adjustable main mirrors
- Close up mirror on passenger side
- Front view mirror
- Roof rails with full air deflector kit
- Roof mounted air horns
- Manual roof hatch with mosquito net
- External storage compartments
- Reverse alarm

Lighting

- H7 headlights
- LED daytime running lights
- End outline marker – White LED
- Identification lamp – Amber LED
- Driving lights in sun visor
- Spot and fog lights in bumper
- Boarding step lights
- Turntable light

Safety

- Driver seat belt pretensioner
- Driver's air bag
- Lane departure warning (LDW)
- Advanced emergency braking (AEB)
- Adaptive cruise control (ACC)

Interior Equipment

- Premium driver's seat with armrests
- Fully adjustable with lumbar support
- Folding passenger seat
- Black woven trim
- Soft feel black/grey dash with grey trim
- Centre storage and passenger table
- Cruise control and dash display controlled from the steering wheel
- Scania colour dash display featuring rear axle load, hour meter, service and vehicle information
- AM/FM radio, CD player with Bluetooth
- AUX MP3 input
- Phone electrical preparation
- 12V outlet in dash
- FMS Preparation
- Resettable circuit breakers
- Power windows
- Manual climate control with air conditioning
- Refrigerator/freezer under bunk
- Lower Bed, 700 - 900mm extendable bunk
- Curtains for windscreen & doors, bed
- Protective rubber floor mats
- UHF CB radio

Additional Equipment

- 20m tyre inflation hose
- Jack & wheel brace
- Globe kit
- Driver's manual
- Three safety triangles

Notes



SCANIA
Total Transport Solutions
scania.com.au

HEAD OFFICE

212 – 216
Northbourne Rd
Campbellfield, 3061
Tel: (03) 9217 3300

VICTORIA

Scania Campbellfield
212 – 216 Northbourne Rd
Campbellfield, 3061
Tel: (03) 9217 3300

Scania Dandenong

2/66 Greens Rd
Dandenong South, 3175
Tel: (03) 9217 3600

Scania Laverton

125 – 129 Boundary Rd
Laverton, 3026
Tel: (03) 9369 8666

NEW SOUTH WALES

Scania Prestons
16 – 18 Lyn Pde
Prestons, 2170
Tel: (02) 9825 7900

Scania Newcastle

1 Enterprise Drive
Beresfield, 2322
Tel: (02) 9825 7940

K & J Trucks Pty Ltd

Lot 1 Pacific Highway
Boambee, 2450
Tel: (02) 6652 7218

NJ's of Wagga

301 Copland Street
Wagga Wagga, 2650
Tel: (02) 6971 7214

QUEENSLAND

Scania Richlands
149 Archerfield Rd
Richlands, 4077
Tel: (07) 3712 8500

Scania Pinkenba

213 Holt St
Pinkenba, 4008
Tel: (07) 3712 7900

SOUTH AUSTRALIA

Scania Wingfield
218 – 234 Cormack Rd
Wingfield, 5010
Tel: (08) 8406 0200

WESTERN AUSTRALIA

Scania Kewdale
527 – 529 Abernethy Rd
Kewdale, 6105
Tel: (08) 9360 8500

Scania Bunbury

12 Proffitt St
Davenport, 6230
Tel: (08) 9724 6200