

SCANIA STREAMLINE

**R 500, R 560, R 620**  
**6X4 PRIME MOVER**  
Chassis Specification



**SCANIA**  
Total Transport Solutions  
scania.com.au



## R-SERIES

**Distinct, dynamic and sharper than ever, the new Scania R-series sets a new standard in long-haulage truck design and technology.**

Scania's V8 range flattens the road, with seemingly endless torque maintaining momentum whatever the load or terrain. In B-Double, roadtrain, or specialist heavy haulage configuration it copes with high gross weights effortlessly.

# R 500, R 560, R 620

## 6X4 PRIME MOVER

### Chassis Specification

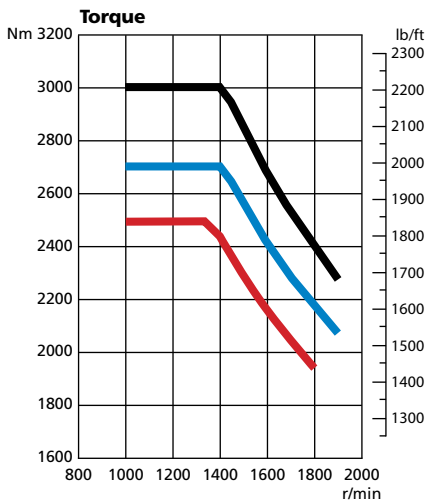
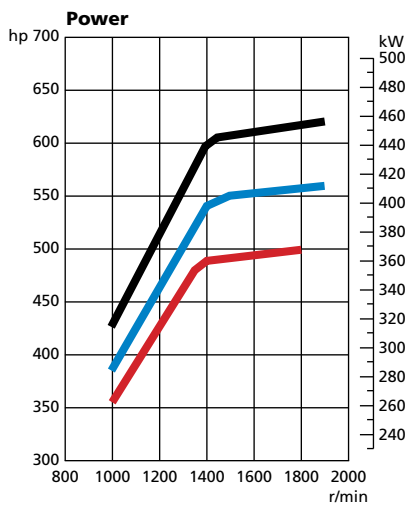

— R 620  
— R 560  
— R 500

### Engine

#### R 620

- Scania DC16 620 15.6 Litre 90° V8
- 620hp (456kW) @ 1800rpm
- 3000Nm (2213ft/lb) @ 1000 - 1400rpm

#### R 560

- Scania DC16 560 15.6 Litre 90° V8
- 560hp (412kW) @ 1800rpm
- 2700Nm (1991ft/lb) @ 1000 - 1400rpm

#### R 500

- Scania DC16 500 15.6 Litre 90° V8
- 500hp (368kW) @ 1800rpm
- 2500Nm (1844ft/lb) @ 1000 - 1400rpm
- Euro5 (ADR 80/03)

### Engine Features

- Scania electronic fuel injection
- Single stage turbocharger
- SCR with catalytic converter
- Centrifugal engine oil filter
- Spin-on turbocharger oil filter
- Cartridge style fuel filter

#### Fan

- 11 Blade, electronically controlled viscous drive

#### Alternator

- Scania 24V, 100amp

#### Compressor

- Knorr 720, twin cylinder, 800L/min with air drier

#### Air Cleaner

- Mounted under front grille

### Gearbox

- Scania GRSO905R, Overdrive 14 speed
- Scania Retarder

### Gearbox Features

- Scania Opticruise
- Gearbox oil cooler
- PTO - Electrical Preparation
- R4100D Retarder

### Front & Rear Axles

#### Front Axle

- Scania AM 740

#### Front Suspension

- 3 x 29 parabolic front springs, 7500kg capacity with anti roll bar

#### Rear Axles

- Scania ADA 1100 Axle housings
- Scania RB662/R660 Differentials
- Ratio 3.42 with power divider and differential locks

#### Rear Suspension

- Scania 4 bag air suspension (19000kg capacity)

#### Brakes

- Scania electronically controlled disc brakes
- EBS with integrated ABS and Traction Control
- Hill hold
- ESP

#### Wheels

- Alcoa aluminum disc polished, 22.5" x 8.25" tubeless rims
- 335mm PCD

#### Tyres

- Front - Bridgestone 295/80 R22.5
- Rear - Bridgestone 295/80 R22.5

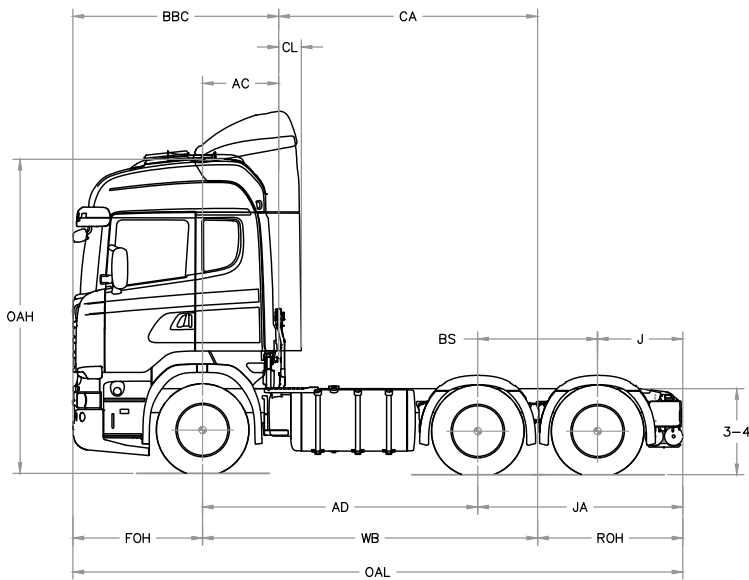

FOH	1460mm	CL	255mm
AD	3100mm	AC	858mm
WB	3775mm	3-4	969-955mm
BS	1350mm	OAL	6870mm
ROH	1635mm	J	960mm
BBC	2318mm	JA	2310mm
CA	2917mm	OAH	3553mm

Turntable mounting angles protrude 40mm above the chassis height.

Tare Weight: Front = 5965kg, Rear = 3750kg, Total = 9715kg.

Tare weight includes, tanks full of fuel and urea. It does not include turntable, bull bar or driver.

Tare weight may vary +/- 5% depending on vehicle specifications.

## Chassis

### Frame

- Scania F950, 270 x 90 x 9.5mm
- Width 770mm

### Paint

- Scania Sub-Grey (Powder Coat)

### Axle Distance

- 3100mm (3775mm wheel base)
- Rear overhang 1635mm

### Fuel & Urea Tanks

- 1030L (1x710L L/H, 1x320L R/H)
- 1x75L Urea tank R/H

### Front Bumper

- Low Mounted FUP compliant bumper
- FUP to ECE R93

### Batteries

- 24V (2x12V, 225amp)
- Mounted rear of chassis
- Chassis electrical connection for auxiliary equipment (Max 200amps)

### Trailer Connections - Brakes

- Trailer Supply & Emergency suzi coils

### Trailer Connections - Electrical

- 12V & 24V trailer light outlets (ISO 1185)
- Trailer lead 7pole to 7pole
- 24V trailer 7pin ABS outlet
- Scania Body Work System with Cable Harness
- Front Mudguards with Spray suppression
- Rear Mudguards with Spray suppression

## Cabin

- Scania CR19 Highline Sleeper cab with four point air suspension
- Cab Strength to ECE R29

### Paint

- Cabin painted Scania white
- With Brilliant Black grille
- Cab colour bumper & front guards

### Exterior Equipment

- Aerodynamic main & spotter mirrors electrically heated
- Electrically adjustable main mirrors
- Close up mirror on passenger side
- Front view mirror
- Roof rails with full air foil kit
- Roof mounted air horns
- Manual roof hatch with mosquito net
- Remote Central Locking
- External storage compartments
- Reverse alarm

### Lighting

- H7 headlights
- Day time running lights – White LED
- End outline marker – White LED
- Identification lights – Amber LED
- Driving lights in sun visor
- Spot lights in bumper
- Fog lights in bumper
- Boarding step lights
- Turntable light

### Safety

- Driver seat belt pretensioner
- Driver's air bag
- Lane departure warning (LDW)
- Advanced emergency braking (AEB)
- Adaptive cruise control (ACC)

## Interior Equipment

- Premium driver's seat with armrests
- Fully adjustable with lumbar support
- Folding passenger seat
- Velour trim
- Soft feel black/grey dash with dark chrome trim
- Centre storage and passenger table with dark chrome trim
- Cruise control and dash display controlled from the steering wheel
- Scania colour dash display featuring rear axle load, hour meter, service and vehicle information
- AM/FM radio, CD player, Bluetooth
- AUX MP3, input
- Phone electrical preparation
- 12V outlet in dash
- FMS Preparation
- Resettable circuit breakers
- Power windows
- Automatic climate control with air conditioning
- Refrigerator/freezer under bunk
- Lower Bed, extendable from 730mm to 900mm
- Upper Bed, 700mm
- Curtains, windscreen & doors, bed
- Protective rubber floor mats
- UHF CB radio

## Additional Equipment

- 20m tyre inflation hose
- Jack & wheel brace
- Globe kit
- Drivers manual
- Three safety triangles

## Notes



**SCANIA**  
Total Transport Solutions  
scania.com.au

### HEAD OFFICE

212 – 216  
Northbourne Rd  
Campbellfield, 3061  
Tel: (03) 9217 3300

### VICTORIA

**Scania Campbellfield**  
212 – 216 Northbourne Rd  
Campbellfield, 3061  
Tel: (03) 9217 3300

### Scania Dandenong

2/66 Greens Rd  
Dandenong South, 3175  
Tel: (03) 9217 3600

### Scania Laverton

125 – 129 Boundary Rd  
Laverton, 3026  
Tel: (03) 9369 8666

### NEW SOUTH WALES

**Scania Prestons**  
16 – 18 Lyn Pde  
Prestons, 2170  
Tel: (02) 9825 7900

### Scania Newcastle

1 Enterprise Drive  
Beresfield, 2322  
Tel: (02) 9825 7940

### K & J Trucks Pty Ltd

Lot 1 Pacific Highway  
Boambee, 2450  
Tel: (02) 6652 7218

### NJ's of Wagga

301 Copland Street  
Wagga Wagga, 2650  
Tel: (02) 6971 7214

### QUEENSLAND

**Scania Richlands**  
149 Archerfield Rd  
Richlands, 4077  
Tel: (07) 3712 8500

### Scania Pinkenba

213 Holt St  
Pinkenba, 4008  
Tel: (07) 3712 7900

### SOUTH AUSTRALIA

**Scania Wingfield**  
218 – 234 Cormack Rd  
Wingfield, 5010  
Tel: (08) 8406 0200

### WESTERN AUSTRALIA

**Scania Kewdale**  
527 – 529 Abernethy Rd  
Kewdale, 6105  
Tel: (08) 9360 8500

### Scania Bunbury

12 Proffitt St  
Davenport, 6230  
Tel: (08) 9724 6200