



SCANIA
Total Transport Solutions
scania.com.au

P 250/310 6X2 RIGID

Chassis Specification



P-SERIES

The Scania P-series cab provides a combination of space and security. With easy cab access, it's ideal for multi-drop duties. No wonder it's the driver's choice.

Perfect for busy distribution duties, the high-tech, clean and frugal five-cylinder 9.0-litre Euro 5 SCR Scania P 250 and P 310 rigid trucks are suitable for a wide variety of body styles to suit a wide range of applications.

P 250/310

6X2 RIGID

Chassis Specification

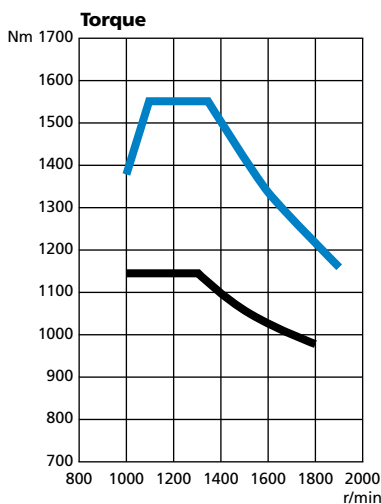
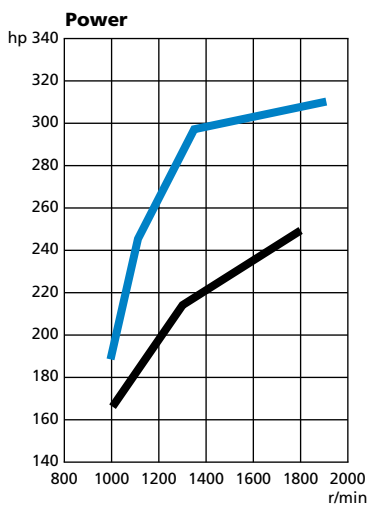

— P 310
— P 250

Engine

310

- Scania DC9 310 9 Litre In-line 5 cylinder
- Power - 310hp (228kW) @ 1900rpm
- Torque - 1550Nm (1143lb/ft) @ 1100 - 1350rpm
- Euro5 (ADR 80/03)

250

- Scania DC9 250 9 Litre In-line 5 cylinder
- Power - 250hp (184kW) @ 1900rpm
- Torque - 1150Nm (850lb/ft) @ 1000 - 1300rpm
- Euro5 (ADR 80/03)

Engine Features

- Scania electronic fuel injection
- Single stage turbocharger
- SCR with catalytic convertor
- Centrifugal engine oil filter
- Spin-on turbo charger filter
- Cartridge style fuel filters

Fan

- Eight blade, electronically controlled viscous drive

Alternator

- Scania 24V, 100amp

Compressor

- Knorr 720, twin cylinder, 800L/min with air dryer

Air Cleaner

- Mounted under grille R/H side

Gearbox

- Scania GRS895, Direct drive 12 speed

Gearbox Features

- Scania Opticruise with Fully Automated Clutch
- PTO - Electrical Preparation

Front & Rear Axles

Front Axle

- Scania AM 860

Front Suspension

- 3 x 29 parabolic front springs 7500kg capacity with anti roll bar

Rear Axle - Driven

- Scania ADA 1100 Axle Housing
- R780 Differential
- Ratio 3.08 with differential lock

Rear Axle - Lazy

- Scania ASA 1000

Rear Suspension

- Scania 4 bag air suspension (19000kg capacity)

Brakes

- Scania electronically controlled disc brakes
- EBS with integrated ABS and Traction Control
- Hill hold

Wheels

- Steel Disc, Silver painted
- 22.5" x 9.00" Tubeless rims
- 335mm PCD

Tyres

- Front - Goodyear 305/70 R22.5
- Rear - Goodyear 305/70 R22.5

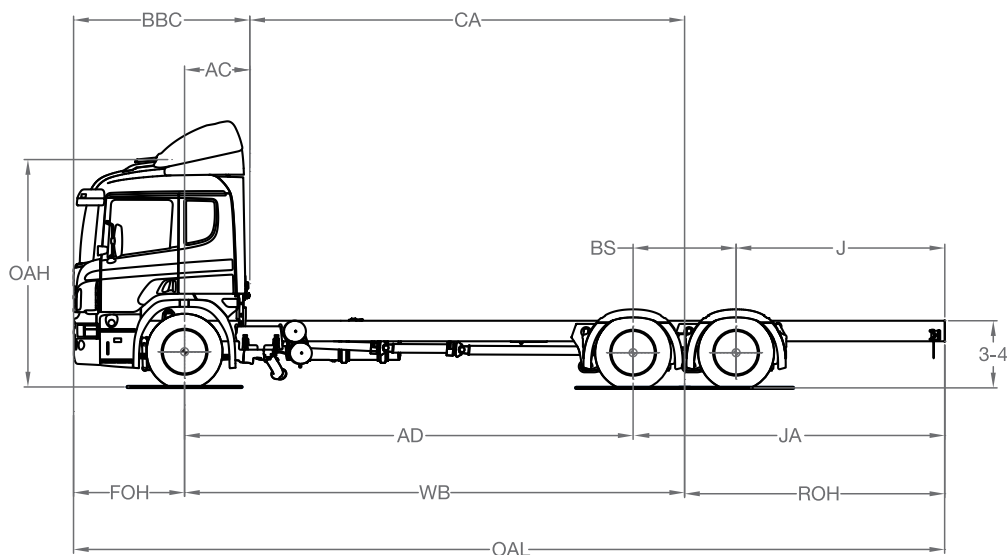

FOH	1455mm	AC	858mm
AD	5900mm	3-4	915-888mm
WB	6575mm	OAL	11355mm
BS	1350mm	J	2650mm
ROH	3325mm	JA	4000mm
BBC	2313mm	OAH	2997mm
CA	5717mm		

Tare Weight: Front = 4865kg, Rear = 3130kg, Total = 7995kg.

Tare weight includes, tanks full of fuel. It does not include turntable, bull bar or driver.

Weight tolerance +/-5%

Chassis

Frame

- Scania F950, 270 x 90 x 9.5mm
- Width 770mm

Paint

- Scania Sub-Grey (Powder Coat)

Axle Distance

- 5900mm (6575mm wheelbase)
- Rear overhang 3325mm

Fuel Tank

- Single 450L steel tank R/H side
- 1 x 50L Urea tank R/H

Front Bumper

- High Mounted FUP compliant bumper
- FUP to ECE R93

Batteries

- 2 x 180amp, 24V L/H side
- Chassis electrical connection for auxiliary equipment (Max 200amps)
- Scania Body Work System
- Cable Harness
- Front Mudguards with spray suppression
- Rear Mudguards with spray suppression

Cabin

- Scania CP19 Normal Sleeper cab
- With four point spring suspension
- Cab Strength to ECE R29

Paint

- Cabin painted Scania white
- With Grey grille

Exterior Equipment

- Aerodynamic main & spotter mirrors electrically heated
- Electrically adjustable main mirror
- Close up mirror on passenger side
- Roof rails with full air foil kit (13cm side)
- Roof mounted air horns
- Manual roof hatch with mosquito net
- Manual Central Locking
- Reverse alarm

Lighting

- H7 headlights
- End outline marker – White LED
- Identification lamp – Amber LED
- Boarding step lights

Safety

- Driver seat belt pretensioner
- Driver's air bag

Interior Equipment

- Medium driver's seat
- Folding passenger seat
- Black woven trim
- Cruise Control & Dash display controlled from steering wheel
- Scania colour dash display featuring rear axle load, hour meter, service and vehicle information
- AM/FM radio, CD player, Bluetooth
- Phone electrical preparation
- 12V outlet in dash
- FMS Preparation
- Resettable circuit breakers
- Power windows
- Air conditioning
- 700mm wide bed with curtains
- Under bed storage
- Protective rubber floor mats
- UHF CB radio

Additional Equipment

- 20m tyre inflation hose
- Jack & wheel brace
- Globe kit
- Drivers manual
- Three safety triangles

Notes



SCANIA
Total Transport Solutions
scania.com.au

HEAD OFFICE

212 – 216
Northbourne Rd
Campbellfield, 3061
Tel: (03) 9217 3300

VICTORIA

Scania Campbellfield
212 – 216 Northbourne Rd
Campbellfield, 3061
Tel: (03) 9217 3300

Scania Dandenong

2/66 Greens Rd
Dandenong South, 3175
Tel: (03) 9217 3600

Scania Laverton

125 – 129 Boundary Rd
Laverton, 3026
Tel: (03) 9369 8666

NEW SOUTH WALES

Scania Prestons
16 – 18 Lyn Pde
Prestons, 2170
Tel: (02) 9825 7900

Scania Newcastle

1 Enterprise Drive
Beresfield, 2322
Tel: (02) 9825 7940

K & J Trucks Pty Ltd

Lot 1 Pacific Highway
Boambee, 2450
Tel: (02) 6652 7218

NJ's of Wagga

301 Copland Street
Wagga Wagga, 2650
Tel: (02) 6971 7214

QUEENSLAND

Scania Richlands
149 Archerfield Rd
Richlands, 4077
Tel: (07) 3712 8500

Scania Pinkenba

213 Holt St
Pinkenba, 4008
Tel: (07) 3712 7900

SOUTH AUSTRALIA

Scania Wingfield
218 – 234 Cormack Rd
Wingfield, 5010
Tel: (08) 8406 0200

WESTERN AUSTRALIA

Scania Kewdale
527 – 529 Abernethy Rd
Kewdale, 6105
Tel: (08) 9360 8500

Scania Bunbury

12 Proffitt St
Davenport, 6230
Tel: (08) 9724 6200