

SCANIA STREAMLINE

**G 440/480**  
**6X4 PRIME MOVER**  
Chassis Specification



**SCANIA**  
Total Transport Solutions  
scania.com.au



## G-SERIES

The Scania G-series trucks are the choice for all-round performance in a broad array of applications.

Scania's G 440/480 is suitable for local, regional, or interstate haulage operations.

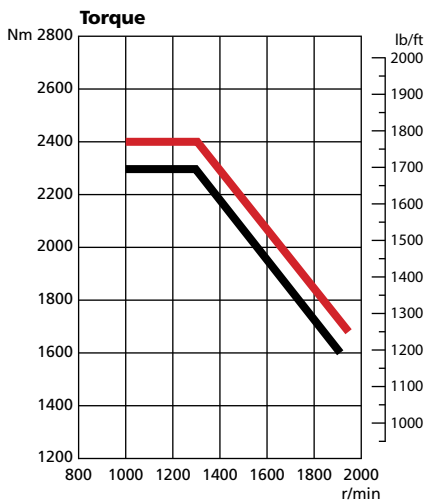
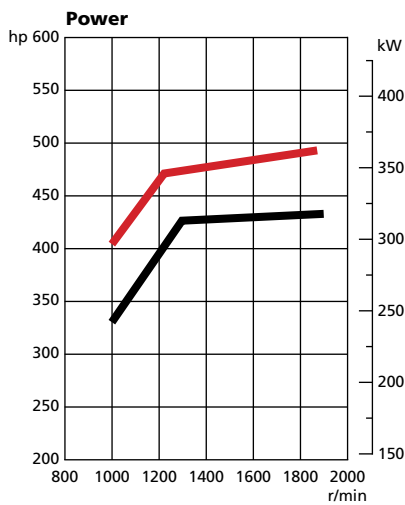

— G 480  
— G 440

## Engine

### 480

- Scania DC 13 480 12.7 Litre In-line 6 cylinder engine
- Power - 480hp (353kW) @1900rpm
- Torque - 2400Nm (1700ft/lb) @1000 - 1350rpm
- Euro 5 (ADR80/03)

### 440

- Scania DC 13 440 12.7 Litre In-line 6 cylinder engine
- Power - 440hp (324kW) @1900rpm
- Torque - 2300Nm (1696ft/lb) @1000 - 1300rpm
- Euro 5 (ADR80/03)

## Engine Features

- Scania electronic fuel injection
- Single stage turbocharger
- SCR with catalytic converter
- Centrifugal engine oil filter
- Spin-on turbocharger oil filter
- Cartridge style fuel filters

### Fan

- 11 Blade, electronically controlled viscous drive

### Alternator

- Scania 24V, 100amp

### Compressor

- Knorr 720, twin cylinder, 800L/min with air drier

### Air Cleaner

- Mounted under the grille R/H side

## Gearbox

- Scania GRSO905R, Overdrive 14 speed
- Scania Retarder

## Gearbox Features

- Scania Opticruise with fully automatic clutch
- Gearbox oil cooler
- PTO - Electrical Preparation
- R4100D retarder

## Front & Rear Axles

### Front Axle

- Scania AM 740

### Front Suspension

- 2 x 32 parabolic front springs 7100kg capacity with anti roll bar

### Rear Axles

- Scania ADA 1103 Axle housings
- Scania RB662/R660 Differentials
- Ratio 3.42 with power divider and differential locks

### Rear Suspension

- Scania 4 bag air suspension (19000kg capacity)

### Brakes

- Scania electronically controlled disc brakes
- EBS with integrated ABS and Traction Control
- Hill hold

### Wheels

- Steel disc painted silver
- 22.5" x 8.25" Tubeless rims
- 335mm PCD

### Tyres

- Front - Bridgestone 295/80 R22.5
- Rear - Bridgestone 295/80 R22.5

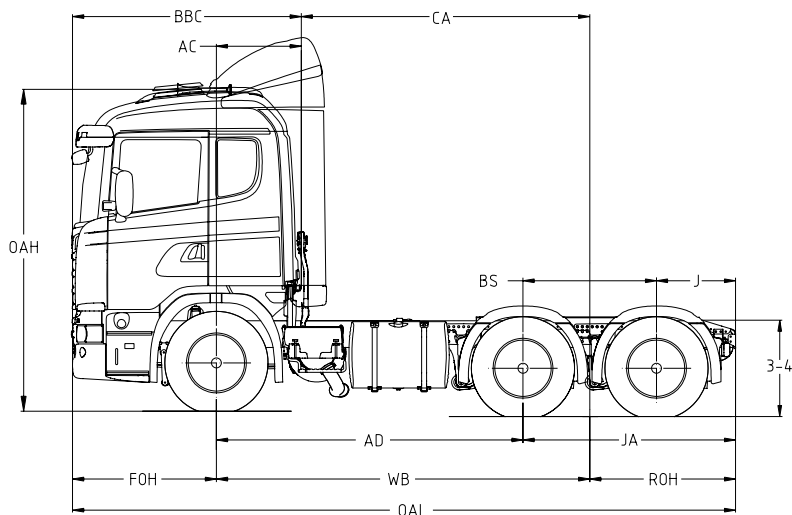

FOH	1455mm	AC	858mm
AD	3100mm	3-4	997-974mm
WB	3775mm	OAL	6705mm
BS	1350mm	J	800mm
ROH	1475mm	JA	2150mm
BBC	2313mm	OAH*	3270mm
CA	2917mm		

Turntable mounting angles protrude 40mm above the chassis height.

Tare Weight: Front = 5145kg, Rear = 3575kg, Total = 8990kg.

Tare weight includes, tanks full of fuel. It does not include turntable, bull bar or driver.

Tare weight may vary +/- 5% depending on vehicle specifications.

\* Depend on chasis height and tyre size.

## Chassis

### Frame

- Scania F950, 270 x 90 x 9.5mm
- External Width 770mm starting 2055mm behind first front axle

### Paint

- Scania Sub-Grey (Powder Coat)

### Axle Distance

- 3100mm (3775mm wheel base)
- Rear overhang 1475mm

### Fuel & Urea Tanks

- 700L (1x400L L/H, 1x300L R/H)
- 1 x 75L Urea tank R/H

### Front Bumper

- High Mounted FUP compliant bumper
- FUP to ECE R93

### Batteries

- 24V (2x12V, 180amp) L/H Side
- Chassis electrical connection for auxiliary equipment (Max 200amps)

### Trailer Connections - Brakes

- Trailer Supply & Emergency suzi coils

### Trailer Connections - Electrical

- 24V trailer light outlets (ISO 1185)
- Trailer lead 7pole to 7pole
- 24V trailer 7pin ABS outlet
- Scania Body Work System with Cable Harness
- Front Mudguards with Spray suppression
- Rear Mudguards with Spray suppression

## Cabin

- Scania CG19 Normal Sleeper cab with four point spring suspension
- Cab Strength to ECE R29

### Paint

- Cabin painted Scania white
- With Brilliant Silver grille

### Exterior Equipment

- Aerodynamic main & spotter mirrors electrically heated
- Electrically adjustable main mirrors
- Close up mirror on passenger side
- Roof rails with full air deflector kit
- Roof mounted air horns
- Manual roof hatch with mosquito net
- Manual central locking
- External storage compartments
- Front view mirror
- Reverse alarm

### Lighting

- H7 headlights
- LED daytime running lights
- End outline marker - White LED
- Identification lamp - Amber LED
- Spot and fog lights in bumper
- Boarding step lights
- Turntable light

### Safety

- Driver seat belt pretensioner
- Driver's air bag
- Active safety support
- Lane departure warning (LDW)
- Advanced emergency braking (AEB)
- Adaptive cruise control (ACC)
- Electronic stabiliser program (ESP)

## Interior Equipment

- Premium driver's seat with armrests
- Fully adjustable with lumbar support
- Folding passenger seat
- Black woven trim
- Cruise control and dash display controlled from the steering wheel
- Scania colour dash display featuring rear axle load, hour meter, service and vehicle information
- AM/FM radio, CD player, Bluetooth
- AUX MP3, input
- Phone electrical preparation
- 12V outlet in dash
- FMS Preparation
- Resettable circuit breakers
- Power windows
- Manual climate control with air conditioning
- 700mm wide bed
- Curtains, windscreen & doors, bed
- Protective rubber floor mats
- UHF CB radio

## Additional Equipment

- 20m tyre inflation hose
- Jack & wheel brace
- Globe kit
- Drivers manual
- Three safety triangles

## Notes



**SCANIA**  
Total Transport Solutions  
scania.com.au

### HEAD OFFICE

212 – 216  
Northbourne Rd  
Campbellfield, 3061  
Tel: (03) 9217 3300

### VICTORIA

**Scania Campbellfield**  
212 – 216 Northbourne Rd  
Campbellfield, 3061  
Tel: (03) 9217 3300

### Scania Dandenong

2/66 Greens Rd  
Dandenong South, 3175  
Tel: (03) 9217 3600

### Scania Laverton

125 – 129 Boundary Rd  
Laverton, 3026  
Tel: (03) 9369 8666

### NEW SOUTH WALES

#### Scania Prestons

16 – 18 Lyn Pde  
Prestons, 2170  
Tel: (02) 9825 7900

#### Scania Newcastle

1 Enterprise Drive  
Beresfield, 2322  
Tel: (02) 9825 7940

### QUEENSLAND

#### Scania Richlands

149 Archerfield Rd  
Richlands, 4077  
Tel: (07) 3712 8500

#### Scania Pinkenba

213 Holt St  
Pinkenba, 4008  
Tel: (07) 3712 7900

### SOUTH AUSTRALIA

#### Scania Wingfield

218 – 234 Cormack Rd  
Wingfield, 5010  
Tel: (08) 8406 0200

### WESTERN AUSTRALIA

#### Scania Kewdale

527 – 529 Abernethy Rd  
Kewdale, 6105  
Tel: (08) 9360 8500

#### Scania Bunbury

12 Proffitt St  
Davenport, 6230  
Tel: (08) 9724 6200