

SCANIA STREAMLINE

G 440/480
6X2 PRIME MOVER
Chassis Specification



SCANIA
Total Transport Solutions
scania.com.au



G-SERIES

The Scania G-series trucks are the choice for all-round performance in a broad array of applications.

Scania's G 440/480 6x2 is suitable for local, regional or interstate haulage operators. It provides operating benefits with increased payload and reduced servicing costs as well as access to Scania's advanced driver assistance systems, fleet management services and Scania financial services and preventative maintenance packages.

G 440/480

6X2 PRIME MOVER

Chassis Specification

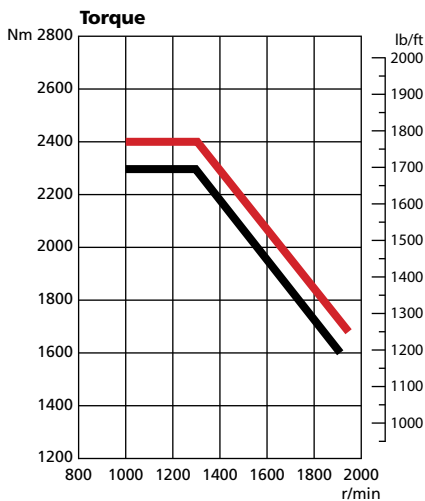
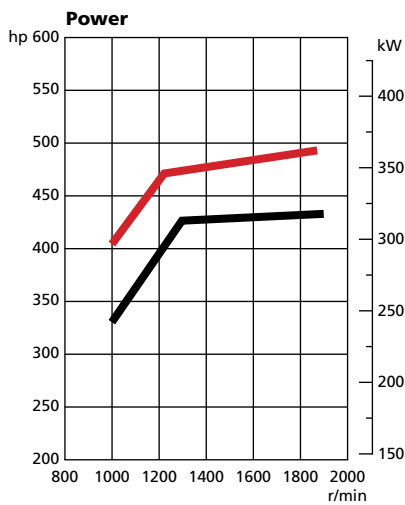

— G 480
— G 440

Engine

G480

- Scania DC 13 480 13 Litre In-line 6 cylinder engine
- Power - 480hp (353kW) @1900rpm
- Torque - 2400Nm (1700ft/lb) @1000 - 1350rpm
- Emission - Euro5 (ADR 80/03)

G440

- Scania DC 13 440 13 Litre In-line 6 cylinder engine
- Power - 440hp (324kW) @1900rpm
- Torque - 2300Nm (1696lb/ft) @1000 - 1300rpm
- Emission - Euro5 (ADR 80/03)

Engine Features

- Scania electronic fuel injection
- Single stage turbocharger
- SCR with catalytic converter
- Centrifugal engine oil filter
- Spin-on turbocharger oil filter
- Cartridge style fuel filters

Fan

- 11 Blade, electronically controlled viscous drive

Alternator

- Scania 24V, 100amp

Compressor

- Knorr 720, twin cylinder, 800L/min with air drier

Air Cleaner

- Mounted under the grille R/H side

Gearbox

- Scania GRS905R, Direct drive 14 speed
- Scania Retarder

Gearbox Features

- Scania Opticruise with fully automatic clutch
- Gearbox oil cooler
- PTO - Electrical Preparation
- R4100D Retarder

Front & Rear Axles

Front Axle

- Scania AM 740

Front Suspension

- 2 x 32 parabolic front springs 7100kg capacity with anti roll bar

Rear Axle - Driven

- Scania ADA 1103 Axle housing
- Scania R780 Differential
- Ratio 2.71 with differential lock

Rear Axle - Lazy

- Scania ASA 1003

Rear Suspension

- Scania 4 bag air suspension (19000kg capacity)

Brakes

- Scania electronically controlled disc brakes
- EBS with integrated ABS and Traction Control
- Hill hold

Wheels

- Steel disc wheels painted silver
- 22.5" x 8.25" Tubeless rims
- 335mm PCD
- ESP

Tyres

- Front - Bridgestone 295/80 R22.5
- Rear - Bridgestone 295/80 R22.5

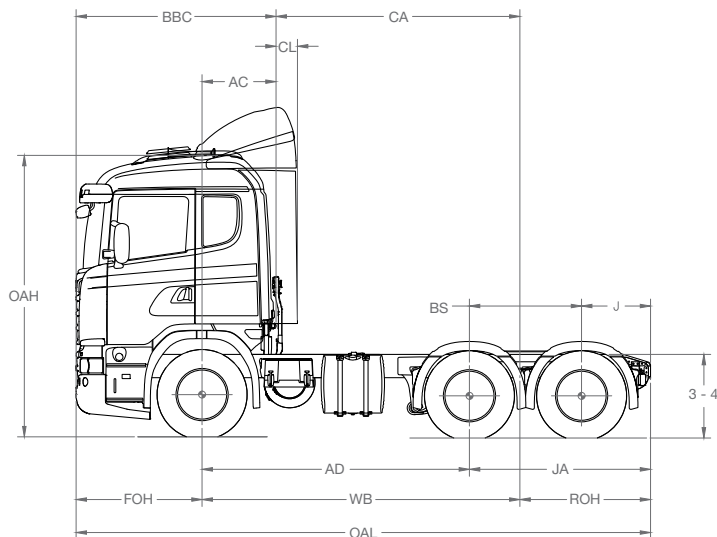

FOH	1455mm	AC	858mm
AD	3100mm	3-4	997-974mm
WB	3750mm	OAL	6655mm
BS	1300mm	J	800mm
ROH	1450mm	JA	2100mm
BBC	2313mm	OAH	3270mm
CA	2892mm		

Turntable mounting angles protrude 40mm above the chassis height.

Tare Weight: Front = 5260kg, Rear = 3460kg, Total = 8720kg

Tare weight includes, tanks full of fuel and urea. It does not include turntable, bull bar or driver.

Tare weight may vary +/- 5% depending on vehicle specifications.

* Depend on chassis height and tyre size.

Chassis

Frame

- Scania F950, 270 x 90 x 9.5mm
- Width 770mm

Paint

- Scania Sub-Grey (Powder Coat)

Axle Distance

- 3100mm (3750mm wheel base)
- Rear overhang 1450mm

Fuel Tanks

- 700L (1x400L L/H, 1x300L R/H)
- 1 x 75L Urea tank R/H

Front Bumper

- High Mounted FUP compliant bumper
- FUP to ECE R93

Batteries

- 24V (2x12V, 180amp) L/H Side
- Chassis electrical connection for auxiliary equipment (Max 200amps)

Trailer Connections - Brakes

- Trailer Supply & Emergency suzi coils

Trailer Connections - Electrical

- 24V trailer light outlets (ISO 1185)
- Trailer lead 7pole to 7pole
- 24V trailer 7pin ABS outlet
- Scania Body Work System with Cable Harness
- Front Mudguards with Spray suppression
- Rear Mudguards with Spray suppression

Cabin

- Scania CG19 Normal Sleeper cab with four point spring suspension
- Cab Strength to ECE R29

Paint

- Cabin painted Scania white
- With Brilliant Silver grille

Exterior Equipment

- Aerodynamic main & spotter mirrors electrically heated
- Electrically adjustable main mirrors
- Close up mirror on passenger side
- Roof rails with full air deflector kit
- Roof mounted air horns
- Manual roof hatch with mosquito net
- Manual central locking
- External storage compartments
- Reverse alarm

Lighting

- H7 headlights
- LED daytime running lights
- End outline marker - White LED
- Identification lamp - Amber LED
- Spot and fog lights in bumper
- Boarding step lights
- Turntable light

Safety

- Driver seat belt pretensioner
- Driver's air bag
- Active safety support
- Lane departure warning (LDW)
- Advance emergency braking (AEB)
- Adaptive cruise control (ACC)

Interior Equipment

- Premium driver's seat with armrests
- Fully adjustable with lumbar support
- Folding passenger seat
- Black woven trim
- Cruise control and dash display controlled from the steering wheel
- Scania colour dash display featuring rear axle load, hour meter, service and vehicle information
- AM/FM radio, CD player with bluetooth
- AUX MP3, input
- Phone electrical preparation
- 12V outlet in dash
- FMS Preparation
- Resettable circuit breakers
- Power windows
- Manual climate control with air conditioning
- 700mm wide bed
- Curtains, windscreen & doors, bed
- Protective rubber floor mats
- UHF CB radio

Additional Equipment

- 20m tyre inflation hose
- Jack & wheel brace
- Globe kit
- Drivers manual
- Three safety triangles

Notes



SCANIA
Total Transport Solutions
scania.com.au

Head Office

212 – 216 Northbourne Rd
Campbellfield, 3061
Tel: (03) 9217 3300

Scania VIC

(Campbellfield)
212 – 216 Northbourne Rd
Campbellfield, 3061
Tel: (03) 9217 3300

Scania VIC

(Dandenong)
2/66 Greens Rd
Dandenong South, 3175
Tel: (03) 9217 3600

Scania VIC

(Laverton)
125 – 129 Boundary Rd
Laverton, 3026
Tel: (03) 9369 8666

Scania NSW

(Prestons)
16 – 18 Lyn Pde
Prestons, 2170
Tel: (02) 9825 7900

Scania NSW

(Newcastle)
1 Enterprise Drive
Beresfield, 2322
Tel: (02) 9825 7940

Scania QLD

(Richlands)
149 Archerfield Rd
Richlands, 4077
Tel: (07) 3712 8500

Scania QLD

(Pinkenba)
213 Holt St
Pinkenba, 4008
Tel: (07) 3712 7900

Scania SA

(Wingfield)
218 – 234 Cormack Rd
Wingfield, 5010
Tel: (08) 8406 0200

Scania WA

(Kewdale)
527 – 529 Abernethy Rd
Kewdale, 6105
Tel: (08) 9360 8500

Scania WA

(Bunbury)
12 Proffitt St
Davenport, 6230
Tel: (08) 9724 6200