



R 540

6X4 PRIME MOVER

CHASSIS SPECIFICATION



SCANIA

R 540

6X4 PRIME MOVER

CHASSIS SPECIFICATION

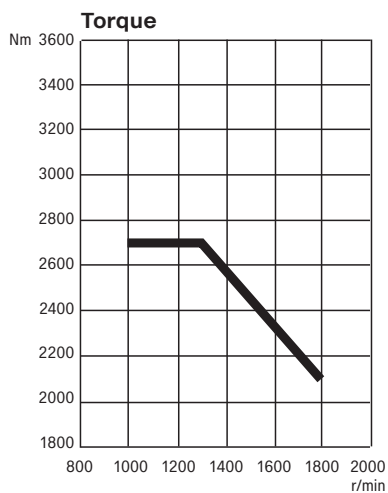
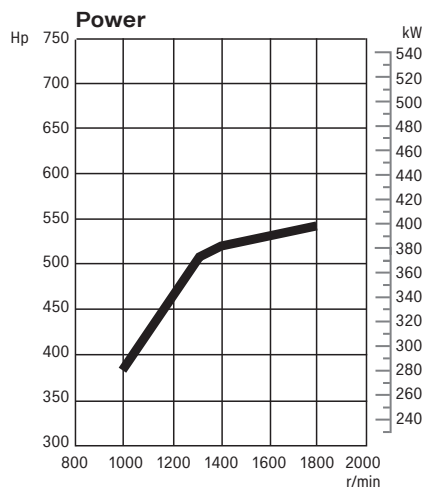

ENGINE

- Scania DC 13 540 12.7 Litre In-line 6 cylinder
- Power – 540 hp (397 kW) @1800 rpm
- Torque – 2700 Nm (1990 lb-ft) @1000 – 1300 rpm
- Euro6

ENGINE FEATURES

- Scania XPI fuel injection
- Fixed geometry turbocharger
- SCR with catalytic converter
- Centrifugal engine oil filter
- Spin-on turbocharger oil filter
- Cartridge style fuel filters

FAN

- Electronically controlled viscous drive

ALTERNATOR

- Scania 24 V, 100 amp

COMPRESSOR

- Knorr 720, twin cylinder, 800 L/min with air drier

AIR CLEANER

- Mounted under the grille RH side

GEARBOX

- Scania GRS0905R, Overdrive 14 speed
- With Scania Retarder

GEARBOX FEATURES

- Scania Opticruise with Fully Automated Clutch
- PTO – Electrical Preparation
- R3500 Retarder
- Refrigerant air oil cooler gearbox

FRONT & REAR AXLES

FRONT AXLES

- Scania AM420S

FRONT SUSPENSION

- 3 x 29 parabolic front springs 7500 kg capacity with anti roll bar

REAR AXLES

- Scania AD200SA axle housings
- Scania RB662 Differentials
- Ratio 3.42 with power divider and differential locks

REAR SUSPENSION

- Scania 4 bag air suspension (19,000 kg capacity)
- Load transfer

BRAKES

- Scania electronically controlled disc brakes
- Electro-pneumatic park brakes
- EBS with integrated ABS and Traction Control
- Hill hold

WHEELS

- Alcoa aluminium DuraBright
- 22.5" x 8.25" Tubeless rims
- 335 mm PCD

TYRES

- Front – Continental 295/80R22.5
- Rear – Continental 295/80R22.5

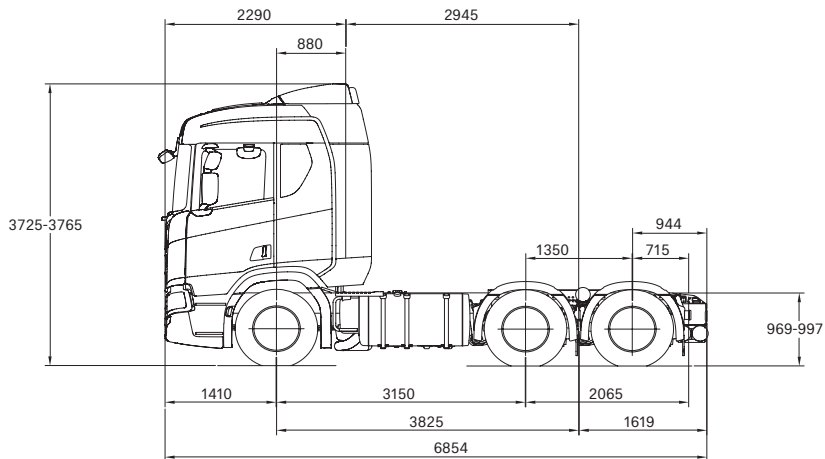

Turntable mounting angles protrude 40 mm above the chassis.

Tare Weight: Front = 5949 kg, Rear = 3842 kg, Total = 9789 kg

Tare Weight includes tanks full of fuel. It does not include turntable, bullbar or driver.

Weight Tolerance +/- 5%

CHASSIS

FRAME

- Scania F950 (270 x 90 x 9.5) mm
- Width 770mm
- Cab Strength to ECE R29

PAINT

- Scania Sub-Grey (Powder Coat)

AXLE DISTANCE

- 3150 mm (3825 mm wheelbase)
- Rear overhang 1475 mm

FUEL TANKS & UREA

- 1030 L (1x710 L LH, 1x320 L RHS)
- 1x105 L Urea Tank RH

FRONT BUMPER

- Normal FUP compliant bumper
- FUP to ECE R93

BATTERIES

- 24 V (2x12 V, 230amp) mounted rear
- Chassis electrical connection for auxiliary equipment (Max 200 amps)

TRAILER CONNECTIONS - BRAKES

- Trailer Supply & Emergency suzi coils

TRAILER CONNECTIONS - ELECTRICAL

- 12V & 24V trailer light outlet (ISO 1185)
- Trailer lead 7-pole to 7-pole
- Scania Body Work System with Cable Harness
- Front Mudguards with Spray Suppression
- Rear Mudguards with Spray Suppression

CABIN

- Scania CR20 Normal Height Sleeper cab with four point spring suspension
- Electric cab tilt

PAINT

- Cabin painted Ivory white with Steel Grey and Brilliant Silver grille

MIRRORS

- Aerodynamic main & spotter mirrors electrically heated
- Electrically adjustable main mirrors
- Close up mirror on passenger side
- Front view mirror

EXTERIOR EQUIPMENT

- Roof rails with full air foil kit
- Electric roof hatch with mosquito net
- Remote Central Locking
- Reverse alarm
- External storage compartments

LIGHTING

- LED headlights
- End outline marker – White LED
- Identification lights – White LED
- Boarding step lights
- Turntable light

SAFETY

- Driver and passenger side curtain air bag
- Driver and passenger seat belt pretensioner
- Driver steering wheel air bag
- Electronic stabiliser program (ESP)
- Lane departure warning (LDW)
- Advanced emergency braking (AEB)
- Adaptive cruise control (ACC)
- Auto Hill Hold
- Rain sensor windows

INTERIOR EQUIPMENT

- Premium driver's seat with armrest
- Medium A passenger seat with armrest
- Velour black trim
- Cruise Control & Dash display controlled from the steering wheel
- Scania 7 inch colour dash display featuring rear axle load, hour meter, service and vehicle information
- Premium 7 inch infotainment system
- Phone electrical preparation
- AUX MP3 input
- 12 V outlet in dash
- FMS Preparation
- Resettable circuit breakers
- Power windows
- Automatic climate control with air conditioning
- Bed extendable from 800mm to 1000mm wide
- Refrigerator/freezer under bunk
- Curtains windscreen, doors & bed
- Protective rubber floor mats
- UHF CB Radio

ADDITIONAL EQUIPMENT

- 20 m tyre inflation hose
- Jack & wheel brace
- Globe kit
- Driver's manual
- Three safety triangles

For more information contact your
Scania branch or local dealer.

HEAD OFFICE

212 – 216 Northbourne Rd
Campbellfield, 3061
Tel: (03) 9217 3300

VICTORIA

Scania Campbellfield
212 – 216 Northbourne Rd
Campbellfield, 3061
Tel: (03) 9217 3300

Scania Dandenong

2/66 Greens Rd
Dandenong South, 3175
Tel: (03) 9217 3600

Scania Laverton

125 – 129 Boundary Rd
Laverton, 3026
Tel: (03) 9369 8666

NEW SOUTH WALES

Scania Prestons

16 – 18 Lyn Pde
Prestons, 2170
Tel: (02) 9825 7900

Midcoast Trucks

Lot 1 Pacific Highway
Boambee, 2450
Tel: (02) 6652 7218

QUEENSLAND

Scania Richlands

149 Archerfield Rd
Richlands, 4077
Tel: (07) 3712 8500

Scania Pinkenba

213 Holt St
Pinkenba, 4008
Tel: (07) 3712 7900

SOUTH AUSTRALIA

Scania Wingfield

218 – 234 Cormack Rd
Wingfield, 5010
Tel: (08) 8406 0200

WESTERN AUSTRALIA

Scania Kewdale

527 – 529 Abernethy Rd
Kewdale, 6105
Tel: (08) 9360 8500

IMPORTANT. The specifications in this brochure were correct at the time of printing.
All weights and measurements are approximate only. Images in this brochure may
display some features not included in the standard specification. Scania Australia
reserves the right to change specifications without prior notice.

