



SCANIA SAFETY & RESCUE VEHICLES



SCANIA

A CENTURY OF KNOWLEDGE TO THE RESCUE

Back in 1911, at a time when most fire crews were using horse-drawn pumps, the first rescue vehicle rolled out of a Scania factory. Since then, we have been a reliable partner to bodybuilders and fire fighters all over the world. Through narrow city streets, busy airports, remote forests, and vast oil fields we take part in the daily fight to save lives and property.

A world of possibilities on a reliable foundation

Much has changed since the days of one-of-a-kind assembled trucks and superstructures. Today's Scania trucks are produced using standardised, factory-built components. This modularity is the basis for the extraordinary adaptability of our cabs and chassis. It enables countless combinations with a number of proven and reliable standardised components. This offers enormous advantages in the creation of your specialised solutions.

In fact, many consider Scania to have the most versatile range of cabs and chassis available. In the long-term, this also ensures reliability and maximises uptime, because fewer components means faster repairs and service.

Today, more than 100 years after its first rescue vehicle was released, Scania is still a popular choice with fire and rescue teams, as well as bodybuilders. Both for the ability to very precisely meet customer needs, the proven high quality and reliability – but also for a strong dedication to ergonomics and safety for the crew.

This dedication has earned us two priceless attributes among rescue specialists: Their pride and their trust. We never take this position for granted. Because just like our firefighting customers, we leave nothing to chance.



KEEPING SAFETY CREWS SAFE

In this line of work, there are no margins for error. To keep focus on the task at hand – the trust in the equipment must be well established. So just like crews go above and beyond to keep us safe, we need to take every step to do the same for them.

A cab built for safety and ergonomics

With driving and work taking place in dangerous and unpredictable environments, high speeds and dense traffic, the Scania CrewCab is built with a high margin of strength to ensure occupant safety.

Unique side curtain airbags

In addition to the resilient cab frame, pillars, roof and rear wall – our CrewCabs can be fitted with side curtain airbags that act as a barrier to the outside environment, keeping occupants in both the front and rear compartments safe.

Our cab and chassis combinations are designed for high-speed manoeuvrability to help avoid incidents, but we also have extensive experience with keeping all types

of heavy transport vehicles safe in the event of a crash or roll-over. However, although the same reliable high strength chassis and cabs are available both for regular transport operations and rescue vehicles – context is everything. As such we design, simulate and execute real-life crash and roll-over tests that are more specific for realistic rescue vehicle operations. When it comes to safety, a mere "pass" on the legislated requirements is simply not enough for us. As such, Scania's internal standards are both tougher and more comprehensive.

The CrewCab is designed with the EN 1846 in mind and all versions of the CrewCab meet the legal impact and safety requirements set under ECE R29-03 as well as the old Swedish impact test, VVFS.

Modern simulations can go far, but nothing compares to real-world testing. Pushing a vehicle past its limits under controlled conditions is the best way to make sure it can meet all safety requirements in action.



A CREW – NOT JUST PASSENGERS

Rescue vehicles have to be ergonomically designed for action, allowing crews to work quickly, effectively and safely – both in transit and at their destination. A space built for much more than simply moving people from one place to another.

The Scania CrewCab

Our rescue vehicles work in coordination with your crew. Entering and exiting the cab is facilitated by sturdy, well-placed yellow grabrails and wide doors that also swing open at a wide angle. The well-positioned broad steps can either be specified as fixed or foldable with automation when opening the door, which positions the steps more like a staircase. The inside of the cab provides generous space, and the long red seatbelts are easily located. The ergonomically designed driver's station with its high visibility wrap-around windscreen is an asset during challenging call outs and complements the driveability to keep your crew safe and comfortable. With optional additional air conditioning, individual outlets and superior capacity for both heating and cooling in the crew area, working

conditions are improved and time for recovery is shortened.

Scania CrewCabs provide plenty of interior space for a range of safety equipment and tools and can carry up to six crew members with the seats installed from factory. If the bodybuilder fits additional rear facing seats the cab can fit a larger crew. Naturally, for those applications where only two or three people are needed, a short cab, day cab or sleeper cab can be specified.

Factory-built

Scania's CrewCabs are factory-built using our regular industrialised cab manufacturing process, which ensures high precision and uncompromising quality. Just as our other cabs, they are assembled using robotic cells before being docked on the final assembly.

Our adaptable cabs and chassis can be specified and delivered with standard mounting hole patterns, pre-punched top row in the frame or you can specify your own individual hole pattern. Behind the cab the chassis frame is empty to allow easier and further installation of equipment and superstructures. Inside the cab, optional aluminium beams can help with mounting of breathing apparatus or other equipment, and electrical preparations have been made to further facilitate bodybuilder solutions.

The CrewCab can be ordered for a wide range of different wheel configurations and axle distances which allows you to customise the chassis to your demands and requirements for the task at hand.



A spacious interior with high visibility features ensures the optimal working conditions for a crew that needs to use their time in transit getting ready for action. Every second counts.

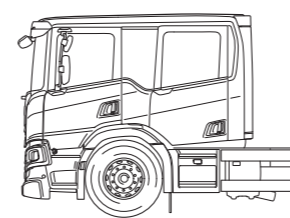

**SCANIA P-SERIES
CREWCAB**

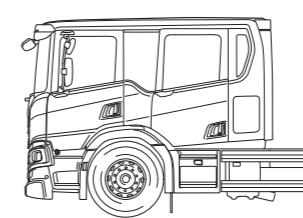

**SCANIA P-SERIES
LONG CREWCAB**

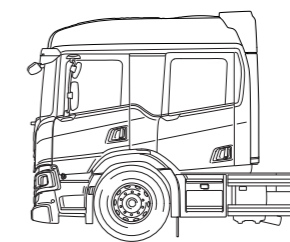

**SCANIA P-SERIES
CREWCAB
NORMAL ROOF**

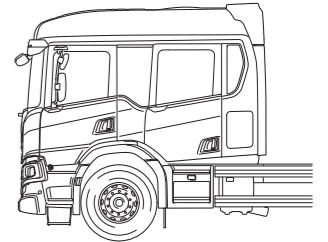

**SCANIA P-SERIES
LONG CREWCAB
NORMAL ROOF**



CHASSIS

THE PERFECT PLATFORM

Our job is to create the foundation for bodybuilders to build on. And that is something that we do very well.

With our unique modular system, we can offer endless combinations with few components. We know that every country, every fire brigade, every situation has its own requirements. And we would never let our specifications stand in the way of performance.

Undeniable strength

Scania's robust chassis gives you enormous torsional stiffness and bending resistance. This combination creates an ideal foundation for the dependable mounting of even the highest turntable ladders and aerial platforms.

Wide range of chassis heights

Low, normal, semi-high, or high? Whatever your environment demands, we have the suspension and axle configuration to fit.

Modular chassis

Our modular concept offers almost limitless combinations of rear overhangs, axle configurations, wheelbases, and frame strengths.

Springs to trust

Simple robust and secure air suspension solutions, as well as parabolic options for the toughest of conditions.

Braking power

We offer lightweight, effective and well-protected disc brakes, as well as high quality drum brakes.

Compact engine installations

Our engine solutions live up to the highest emission standards, while still offering optimal flexibility in your design. Such as our Euro 6

installation, one of the most compact on the market.

Bodywork Communication Interface (BCI)

The Bodywork Communication Interface acts as a bridge between the bodywork and the chassis for all the logic and electronics. This means that for the bodybuilder, electronic components are easy to install and connect, and even easier to program. This gives almost endless possibilities to control both vehicle and bodywork function.



POWERTRAINS

POWER WHEN YOU MOST NEED IT

When lives are at stake reliability is crucial. As is torque. And manoeuvrability. And braking power. And effective gear-changing. And...

In other words, our engines and powertrains have a lot to live up to. That is why we have the technology to deliver all the quality you can expect.

Power from 220–770 hp

With a wide range of Scania engines, you are always free to choose a powertrain optimised for your needs.

Power take-offs in various positions

Our PTO options from factory include both clutch-independent PTOs

(engine- and flywheel-driven), and clutch-dependent PTOs (gearbox-driven), solutions letting your power last through hours of water-pumping.

Emission levels

The Scania engine range offers options in emission levels Euro 3, 4, 5, Euro 6 and China VI.

All geared up

With the choice of Scania comes gearboxes for all needs. No matter if you prefer a fully automatic gearbox

for superior acceleration, or a Scania Opticruise – with or without clutch pedal.

Optimisation for gear ratio

We offer a great variation of options for gear-ratio optimisation. All to let you optimise your driving under any conditions.

All geared up

With the choice of Scania comes gearboxes for all needs and driving styles. Choose between manual or Scania Opticruise. Or make a move for our wide range of fully automated gearboxes, for extra smooth gear-changing and superior acceleration.

Power take-offs in various positions

Our PTO options include gearbox-driven, engine-driven and fly-wheel-driven solutions. With our new option for flywheel driven take-off including clutch, your power will last through hours of water-pumping.

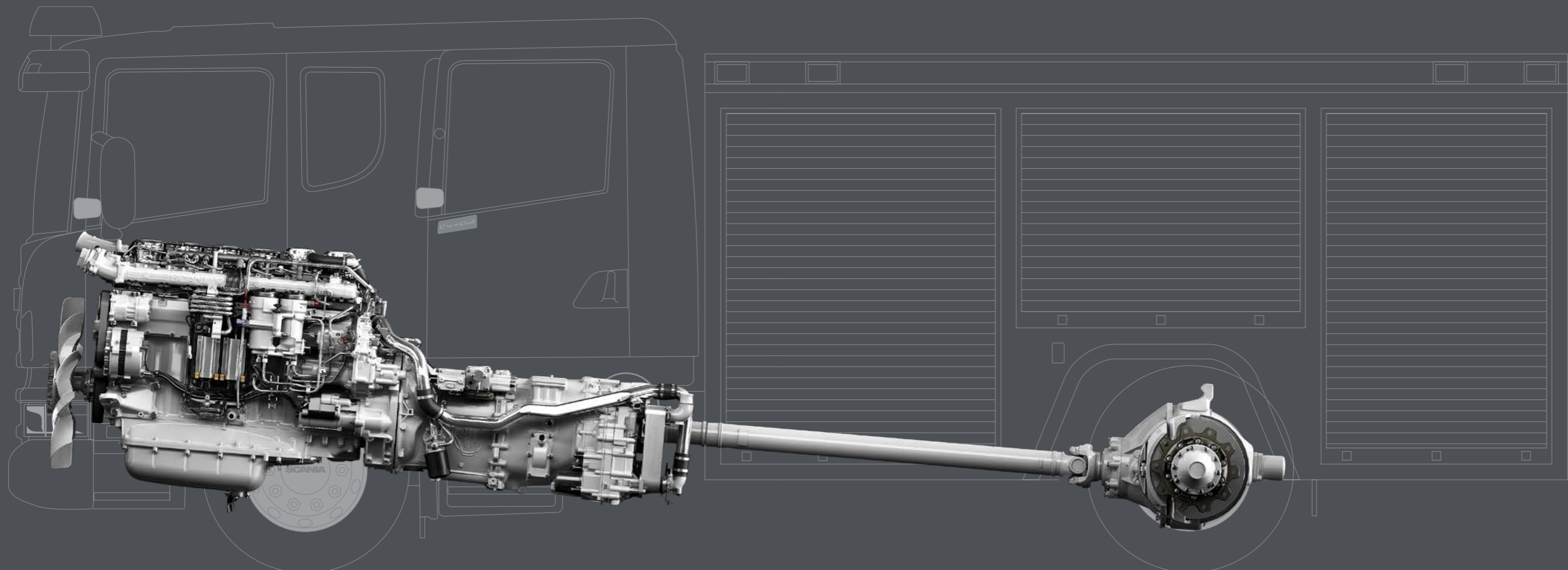
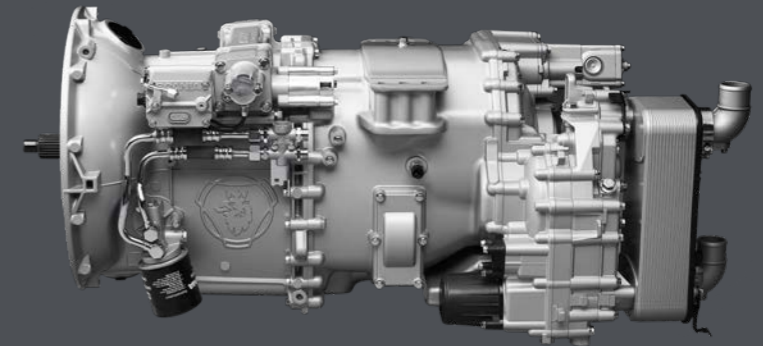

FIRE ENGINE

THE VEHICLE WITH MANY FACES

Fire engines come in countless variations – all to suit different areas, cities and fire brigades – but most specifications share some common traits. They need to transport the crew as well as the tools, equipment and some of the water and foam needed.

The traditional fire engine most commonly used by city and municipal fire brigades is normally built on a 4x2 configuration, carries a water tank with a capacity 1,000–4,000 litres, and up to 1,000 litres of foam mix. They are also equipped with ladders and other rescue equipment – such as cutting tools and mobile power generators.

Always ready – for anything

Rescue vehicles need to be versatile and ready for a wide variety of scenarios, because when it comes to fires, accidents or other emergencies the conditions on site are incredibly dynamic. But the more complex the needs, other applications are also deployed to meet those needs.

Quality that lasts

All fire engines also need to be built with the quality and strength to withstand many years of demanding use driven with high load for short distances. Something that causes a lot of wear, and places high demands on regular maintenance. Through a combination of very high-quality components and our modular design, your vehicles can be properly maintained with minimum downtime. Extending both the service life of the components and ensuring that the fire engine is always ready to save lives.

Tailored to specific needs

In urban environments there are specific requirements on weight

and height to be able to access every part of the operational zone. But fire brigades also operate in rural environments and forests which demand off-road and all-terrain capabilities. It's therefore of great importance to be able to fully tailor the specification to individual needs. So when the chassis, engine, powertrain and cab work together you get a platform that works for every scenario and gives you the possibility to build the type of vehicle that suits your needs.



TURNTABLE LADDER

REACHING FOR THE SKIES

With a telescopic ladder, your crew can ascend and descend from buildings and hard to reach places. This not only means the crew can get where they're needed, to extinguish fires from above or get into inaccessible locations or tall buildings with blocked stair access, but at the same time it can act as a rescue path for rapidly evacuating trapped people.

With a high reach and the possibility for an articulated tip of the ladder, it's no surprise you'll find ladder trucks in a large majority of fire brigades across the world.

The turntable ladder is powerful tool that is quick to deploy, yet provides a working environment you can always trust, no matter if it's used for moving people, equipment or covering a blaze with a continuous stream of water from above.

Turntable ladder trucks are by many seen as the quintessential fire rescue vehicles. And that's for good reason – they're an incredibly flexible tool that can handle a wide variety of situations.



AERIAL PLATFORM

UNCOMPROMISED ACCESS

When you need a secure work area at a great height or in a complex environment, an aerial platform is your go-to tool. Can be specified to the perfect balance of articulation and reach, or favouring one or the other. Aerial platforms can be built to extend over 100 metres all thanks to a very rigid chassis and stabilising hydraulic legs.

The aerial platform shares most of the usage scenarios with a turntable ladder and can be used for many of the same things, like lifting and moving heavy objects, equipment – or even animals that need to be lifted to safety. In comparison, the

aerial platform however exchanges a bit of the turntable ladder's quick deployment speed for increased stability and reach both vertically and horizontally – making it a very suitable working platform.



CRASH TENDER

AEROSPACE GRADE SAFETY

Airport rescue crews deal with very specific, but often quite extreme circumstances. This means the airport crash tenders are very specialized to these conditions. They are often specified with 4x4 or 6x6 all-wheel drive, fully automatic gearbox and extra powerful engines for maximum acceleration and speed. All to reach an accident site in the shortest time possible.

Flat runways and rough terrain

Considering the terrain surrounding airports, airport rescue vehicles need to handle both on-road and off-road conditions. As such, besides their all-wheel drive they are often equipped with super-single tyres to provide increased ground clearance and a good ability to climb over obstacles.

Extinguishing capacity

The tanks normally have a capacity of 10,000 litres or more of water and

approximately 1,000 litres of foam.

They are also equipped with powerful pumps, usually both on the roof and in the front, that has a capacity of around 6,000 litres per minute meaning more than 10 cubic metres of water can be deployed in less than two minutes.



Airports present very specific and yet widely varying safety challenges. No matter if you need maximum acceleration down a long runway, or reaching an off-road accident site beyond the tarmac – the crash tender will get you there.

WATER/FOAM CARRIER

10,000 LITRES ON BOARD

With a water and foam carrier you can bring your own source of water to places where there's no direct access to on-site water, or while access to a continuous water source is being established. This makes these vehicles very popular support vehicles being able to get in quick, and start containing the situation before it becomes catastrophic.

A water carrier normally holds 10,000 litres of water or more, and usually also carry a foam supply. This may in itself be enough water or foam capacity to fully extinguish some smaller and localised incidents.

When you can't easily or quickly source water at the site where it's needed, a water/foam carrier lets you bring a substantial amount of water and foam along.















CABS AND CHASSIS

With our modular system you have the possibility to tailor the combination of cab and chassis to your specific needs at an unmatched level, without sacrificing on reliability. If you're looking for a cab or chassis option that's not listed here – chances are high we can still make it for you. Don't hesitate to ask.

Cab options

The most common cabs for rescue vehicles are either the CrewCab, or the G, P or L cabs. But if you would prefer a vehicle with an R or S cab, that can be easily arranged.

| | Day cabs | | Short cab | | |
|-----------------|--|---|---|--|---|
| G |  Low |  Normal |  Low | | Scania G-series Robust and well-equipped. Mid-size cabsuitable for a wide range of applications. Engines 280 to 540 hp |
| P |  Low |  Normal |  Low | | Scania P-series Lightweight, economic and comfortable. Compact dimensions paired with full size quality and performance. Engines 220 to 500 hp |
| L |  Low |  Normal |  High | | Scania L-series Tailored for city operations. Low boarding step, great visibility, safe and easy access. Engines 280 to 360 hp |
| CrewCabs | | | | | |
| CREW CAB |  Low |  Normal |  High |  Extra High | Scania P-series CrewCab Comfortable, safe and ergonomic for your crew. Engines 220 to 500 hp |

Axle configuration options

Rescue vehicles chassis from Scania are available in a variety of axle configurations. Contact your Scania dealer to find the best solution for your needs.

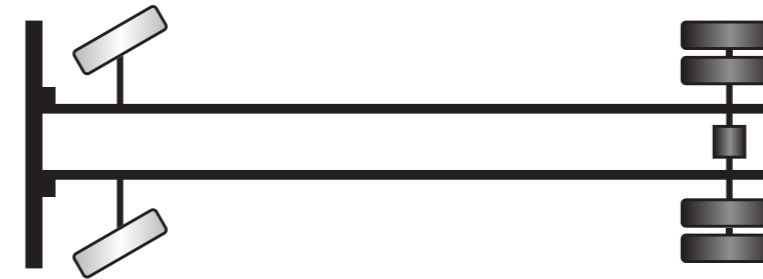

Tractors

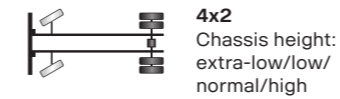

Rigids

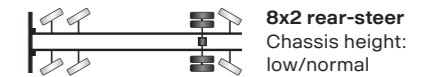

ENGINES, POWER TAKE-OFF AND GEARBOXES

We provide a wide selection of reliable, powerful and fuel-efficient engines all the way from Euro 3 up to Euro 6 emissions standard levels, with multiple PTO options, as well as a selection of both range-splitter and automatic gearboxes.

Power Take-Off

Depending on your needs, some PTO solutions may be preferable to others. For that reason, we offer both gearbox-driven and engine-driven PTO options from factory. For more information, contact your nearest Scania dealer.

Gearboxes

| Gears | Type | Engines | Options |
|--|---------------------|---------------|------------|
| Range-splitter gearboxes | | | |
| 14 gears | Medium-duty gearbox | Up to 2500 Nm | Opticruise |
| 14 gears | Heavy-duty gearbox | Up to 2500 Nm | Opticruise |
| 14 gears | Medium-duty gearbox | Up to 3300 Nm | Opticruise |
| 14 gears | Heavy-duty gearbox | Up to 3300 Nm | Opticruise |
| Automatic gearboxes | | | |
| Automatic gearboxes are available in four options, together with most of the 5- and 6- cylinder engines. | | | |

Euro 6 engines

| Swept volume | Max power | Max torque | Emission control |
|-----------------|-------------------------------|--------------------------|---|
| 6 inline | | | |
| 9-litre | 280 hp (206kW) at 1900 r/min | 1400Nm (1050-1400 r/min) | SCR Without UNECE noise regulation Phase 3 |
| 9-litre | 320 hp (235kW) at 1900 r/min | 1600Nm (1050-1400 r/min) | SCR Without UNECE noise regulation Phase 3 |
| 11-litre | 350 hp (257kW) at 1800 r/min | 1800Nm (950-1360 r/min) | - |
| 11-litre | 390 hp (287kW) at 1800 r/min | 2000Nm (950-1360 r/min) | - |
| 11-litre | 430 hp (316 kW) at 1800 r/min | 2200Nm (950-1360 r/min) | - |
| 13-litre | 370 hp (272kW) at 1800 r/min | 1900Nm (900-1340 r/min) | SCR |
| 13-litre | 410 hp (302kW) at 1800 r/min | 2150Nm (900-1340 r/min) | SCR |
| 13-litre | 450 hp (331kW) at 1900 r/min | 2350Nm (1000-1300 r/min) | SCR |
| 13-litre | 500 hp (368kW) at 1900 r/min | 2550Nm (1000-1300 r/min) | SCR |

Euro 5 engines

| Swept volume | Max power | Max torque | Emission control |
|-----------------|-------------------------------|--------------------------|---|
| 6 inline | | | |
| 9-litre | 280 hp (206kW) at 1900 r/min | 1400Nm (1000-1400 r/min) | SCR Without UNECE noise regulation Phase 3 |
| 9-litre | 320 hp (235kW) at 1900 r/min | 1600Nm (1050-1400 r/min) | SCR Without UNECE noise regulation Phase 3 |
| 11-litre | 350 hp (257kW) at 1800 r/min | 1800Nm (950-1360 r/min) | - |
| 11-litre | 390 hp (287kW) at 1800 r/min | 2000Nm (950-1360 r/min) | - |
| 11-litre | 430 hp (316 kW) at 1800 r/min | 2200Nm (950-1360 r/min) | - |
| 13-litre | 380 hp (279kW) at 1900 r/min | 1975Nm (1000-1300 r/min) | SCR |
| 13-litre | 410 hp (302kW) at 1900 r/min | 2150Nm (1000-1300 r/min) | SCR |
| 13-litre | 440 hp (324kW) at 1900 r/min | 2300Nm (1000-1300 r/min) | SCR |
| 13-litre | 450 hp (331kW) at 1900 r/min | 2350Nm (1000-1300 r/min) | SCR |

Euro 4 engines

| Swept volume | Max power | Max torque | Emission control |
|-----------------|-------------------------------|--------------------------|---|
| 6 inline | | | |
| 9-litre | 280 hp (206kW) at 1900 r/min | 1400Nm (1000-1400 r/min) | SCR Without UNECE noise regulation Phase 3 |
| 11-litre | 350 hp (257kW) at 1800 r/min | 1800Nm (950-1360 r/min) | - |
| 11-litre | 390 hp (287kW) at 1800 r/min | 2000Nm (950-1360 r/min) | - |
| 11-litre | 430 hp (316 kW) at 1800 r/min | 2200Nm (950-1360 r/min) | - |
| 13-litre | 380 hp (279kW) at 1900 r/min | 1975Nm (1000-1300 r/min) | SCR |
| 13-litre | 410 hp (302kW) at 1900 r/min | 2150Nm (1000-1300 r/min) | SCR |
| 13-litre | 440 hp (324kW) at 1900 r/min | 2300Nm (1000-1300 r/min) | SCR |
| 13-litre | 450 hp (331kW) at 1900 r/min | 2350Nm (1000-1300 r/min) | SCR |

Euro 3 engines

| Swept volume | Max power | Max torque | Emission control |
|-----------------|------------------------------|--------------------------|---|
| 5 inline | | | |
| 9-litre | 250 hp (184kW) at 1900 r/min | 1250Nm (1000-1350 r/min) | SCR Without UNECE noise regulation Phase 3 |
| 9-litre | 310 hp (228kW) at 1900 r/min | 1550Nm (1000-1350 r/min) | SCR Without UNECE noise regulation Phase 3 |
| 6 inline | | | |
| 13-litre | 360 hp (265kW) at 1900 r/min | 1800Nm (1000-1350 r/min) | - |
| 13-litre | 410 hp (302kW) at 1900 r/min | 2050Nm (1000-1350 r/min) | - |
| 13-litre | 440 hp (324kW) at 1900 r/min | 2250Nm (1000-1350 r/min) | - |

